

# GF80 Series

## Metal Sealed, Digital, MultiFlo™ Capable, Thermal Mass Flow Controllers & Meters for Gases

Brooks® GF80 thermal mass flow controllers (MFCs) and thermal mass flow meters (MFMs) offer unparalleled performance, reliability, and flexibility for the measurement and control of process gases. At the heart of the GF80 is Brooks' patented 4th generation MultiFlo™ gas and range programmability, making them an optimum choice for process development and research applications or to simplify and reduce cost of spares ownership. The Brooks MultiFlo™ database is built on collecting thousands of native gas measurements on custom NIST traceable metrology to create gas models that account for both thermal and physical differences among gases, far surpassing single point conversion factors.

With a wide range of communication options, the GF80 series provides a powerful yet simple upgrade for existing analog and digital MFCs or MFMs.



Features	Benefits
Metal Seal	High internal to external leak integrity. No periodic replacement of aging seals necessary.
Adaptable Mechanical Configurations	Compact footprint enables easy retrofit to existing systems.
Metrology	Measurement accuracy is traceable to international standards.
MultiFlo™ Gas and Range Programmability with Diagnostics and User Accessible Port	Ability to select new gas calibrations and full-scale ranges without replacement of the mass flow controller. The convenient interface diagnostics port for maximizes service uptime.
Corrosion Resistant Hastelloy® Sensor	Provides unmatched long-term sensor stability ensuring maximum yield and throughput.

# Product Specifications

## GF80

### Performance

Full Scale Flow Range (N <sub>2</sub> Eq.)	3 sccm to 55 slm
Flow Accuracy	±1% S.P. 35 - 100%, ±0.35% F.S. 2 - 35%
Repeatability & Reproducibility	<±0.2% S.P.
Linearity	±0.5% F.S. (included in accuracy)
Response Time (Settling Time)	Normally Closed Valve <1 sec. (within 2% for steps 0 - 10 through 0 - 100%)
Control Range	2 - 100%
MultiFlo™	Optional
Number of Bins	11 bins
Valve Shut Down	<1% of F.S.
Zero Stability	<±0.5% F.S. per year
Pressure Coefficient	0.03% per psi (0 - 50 psi N <sub>2</sub> )
Attitude Sensitivity	<0.25% span change @ 90°C after rezeroing (N <sub>2</sub> @ 50 psi)
Auto Zero	Optional: (When Auto Zero is enabled the device performs the zero function once every time the set point returns to zero. To accomplish, simply provide a zero set point.)
Auto shut-off	The Auto Shut-off feature closes the GF80 valve when the set point drops below 1.5% of full scale
Available Gases	MultiFlo™ Capable

### Ratings

Operating Temperature Range	5 - 50°C (41 - 122 °F)
Maximum Operating Pressure <sup>1</sup>	150 psig (10 bar)
Differential Pressure Range <sup>1</sup>	3 - 860 sccm = 7 - 45 psid, 861 - 7200 sccm = 15 - 45 psid, 7201 - 50000 sccm = 25 - 45 psid Typical pressure drop, high density gases like Argon gas applications require an additional 10 psid differential pressure
Leak Integrity (external)	1x10 <sup>-10</sup> atm. cc/sec He

### Mechanical

Valve Type	Normally Closed, Meter
Primary Wetted Materials	316 Stainless Steel, Hastelloy C-22, 17-7 PH, 430SS
External Seals	316 Stainless Steel
Internal Seals / Valve Seat	316 Stainless Steel
Surface Finish	16µ inch Ra

### Diagnostics & Display

Surface Finish	MFC Health, Network Status
Alarms <sup>1</sup>	Sensor Output, Control Valve Output, Over Temperature, Power Surge/Sag, Network Interruption
Diagnostic / Service Port	RS485 via 2.5mm jack

### Compliance

Environmental Compliance	CE: EN6126: 2006 (FCC Part 15 & Canada IC-subset of CE testing) Designed to meet EN61010 RoHS
--------------------------	---

<sup>1</sup> Application specific lower supply pressure and/or lower differential pressure operation available through Brooks Customer Special Request (CSR) process.

# Product Specifications

	RS485 <sup>2</sup>	Profibus	DeviceNet™
<b>Communication Protocol</b>			
<b>Electrical Connection</b>	1 x 15-pin Male Sub-D, (A)	1 x 15-pin Male Sub-D / 1 x 9-pin Female Sub-D	1 x M12 with threaded coupling nut, (B)
<b>Analog I/O</b>	0 - 5 V, 0 - 10 V, 0 - 20 mA, 4 - 20 mA	0 - 5 V, 0 - 20 mA, 4 - 20 mA	N/A
<b>Power Max. / Purge</b>	From +12 Vdc to +24 Vdc: 7 Watt / 8 Watt	From +13.5 Vdc to +27 Vdc: 7 Watt / 8 Watt	From +11 Vdc to +25 Vdc: 13.6 Watt / 15.0 Watt

## Voltage Setpoint Specifications

<b>Nominal Range</b>	0 - 5 Vdc or 0 - 10 Vdc	0 - 5 Vdc	N/A
<b>Full Range</b>	0 - 11 Vdc	0 - 5.5 Vdc	N/A
<b>Absolute Max</b>	25 V (without damage)		N/A
<b>Input Impedance</b>	192 kOhms		N/A
<b>Required Max. Sink Current</b>	0.002 mA		N/A

## Current Setpoint

<b>Nominal Range</b>	4 - 20 mA or 0 - 20 mA		N/A
<b>Full Range</b>	0 - 22 mA		N/A
<b>Absolute Max</b>	25 mA (without damage)		N/A
<b>Input Impedance</b>	250 Ohms	125 Ohms	N/A

## Flow Output (Voltage) Specifications

<b>Nominal Range</b>	0 - 5 Vdc or 0 - 10 Vdc	0 - 5 Vdc	N/A
<b>Full Range</b>	N(-0.5) - 11 Vdc	0 - 5.5 Vdc	N/A
<b>Min Load Resistance</b>	1 kOhms	1 kOhms	N/A

## Flow Output (Current) Specifications

<b>Nominal Range</b>	0 - 20 mA or 4 - 20 mA		N/A
<b>Full Range</b>	0 - 22 mA (@ 0 - 20 mA); 3.8 - 22 mA (@ 4 - 20 mA)		N/A
<b>Max. Load</b>	400 Ohms (for supply voltage: 12 - 24 Vdc)		N/A

## Analog I/O Alarm Output<sup>3</sup>

<b>Type</b>	Open Collector	N/A
<b>Max. Closed (On) Current</b>	25 mA	N/A
<b>Max. Open (Off) Leakage</b>	1µA	N/A
<b>Max. Open (Off) Voltage</b>	30 Vdc	N/A

## Analog I/O Valve Override Signal Specifications<sup>4</sup>

<b>Floating / Unconnected</b>	Instrument controls valve to command set point	N/A
<b>VOR &lt; 0.3 Vdc</b>	Valve Closed	N/A
<b>1 Vdc &lt; VOR &lt; 4 Vdc</b>	Valve Normal	N/A
<b>VOR &gt; 4.8 Vdc</b>	Valve Open	N/A
<b>Input Impedance</b>	800 kOhms	N/A

<sup>2</sup>There are three (3) RS485 Protocols:

S-Protocol is a RS485 communication based on HART® command set.

L-Protocol is a RS485 communication compatible with legacy Unit® and Celerity® devices.

A-Protocol is a RS485 communication compatible with Aera® mass flow devices.

<sup>3</sup>The Alarm Output is an open collector or "contact type" that is CLOSED (on) whenever an alarm is active. The Alarm Output may be set to indicate any one of various alarm conditions.

<sup>4</sup>The Valve Override Signal (VOR) is implemented as an analog input which measures the voltage at the input and controls the valve based upon the measured reading as shown in this section.

# Product Dimensions

## GF80 Series

Analog / RS485

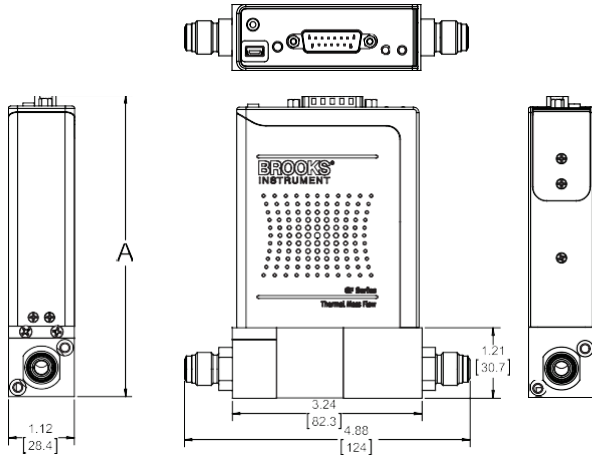

Profibus

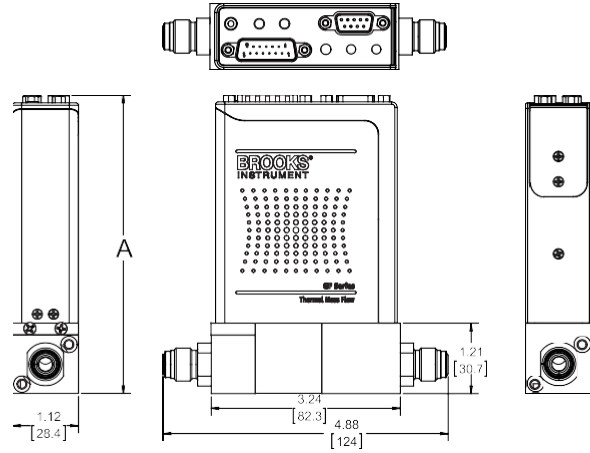

DeviceNet

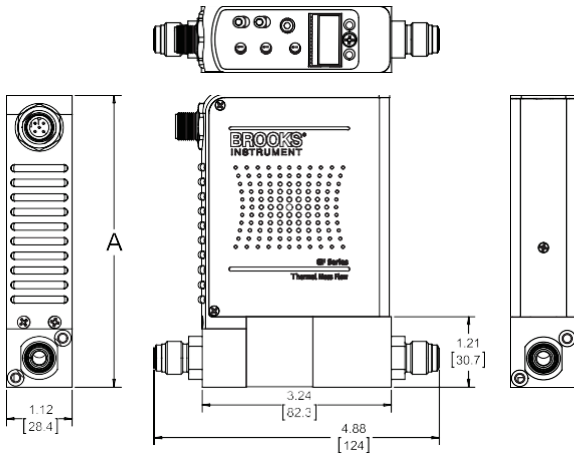

Analog/RS485, Profibus, and DeviceNet Models

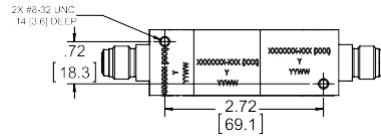

Configuration	Dim A
Analog/RS485	5.16in [131.1mm]
Profibus	5.11in [129.8mm]
DeviceNet	5.00in [127mm]

## Base I/O Options

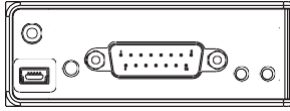

Description: Industry standard  
Analog / RS485 S Protocols

### Model Code Option: S0/S1/S5

Pin	Description
1	Setpoint Common
2	Flow Output (0 - 5 V, 0 - 10 V)
3	Alarm Out
4	Flow Output (0 - 20mA, 4 - 20 mA)
5	Power Supply (+12 V to +24 Vdc)
6	NC
7	Setpoint Input (0 - 20mA, 4 - 20 mA)
8	Setpoint Input (0 - 5 V, 0 - 10 V)
9	Power Common
10	Flow Out Common
11	NC
12	Valve Override Input
13	Reserved
14	RS485B
15	RS485A

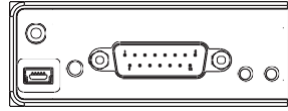

Description: Industry standard  
Analog / RS485 L Protocols

### Model Code Option: L0/L1/L4/L5

Pin	Description
1	Setpoint Common
2	Flowpoint Output (0 - 5 V)
3	Alarm Out
4	Flow Output (0 - 20mA, 4 - 20 mA)
5	Power Supply (13.5 - 27 V)
6	NC
7	Setpoint Input (0 - 20 mA, 4 - 20 mA)
8	Setpoint Input (0 - 5 V)
9	Power Common
10	Flow Out Common
11	NC
12	Valve Override Input
13	Reserved
14	NC
15	NC

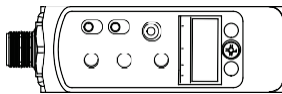

Description: Industry standard  
DeviceNet

### Model Code Option: DX

Pin	Description
1	Drain
2	V+ (11 - 25 Vdc)
3	V-
4	CAN-H
5	CAN-L

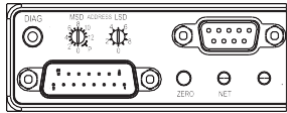

Description: Industry standard  
Profibus

### Model Code Option: P0/P4/P5

Pin	Description
1	NC
2	NC
3	RXD / TXD - B - Red Wire
4	NC
5	Ground
6	+5 Vdc
7	NC
8	RXD/TXD - A - Green Wire
9	NC

# Model Code

Code Description	Code Option	Option Description
I. Base-Model Code	GF080	Metal / Flow Range (0-55 slpm)
II. Configurability	C	MultiFlo™ Capable. Standard Bins or specific gas range may be selected
	X	Not MultiFlo™ Capable. Specific gas/range required
III. Special Application	XX	Standard
IV. Valve Configuration	C	Normally Closed Valve
	M	Meter (No Valve)
V. Gas or SH MultiFlo™ Bin	XXXX XXXX	Specific Gas Code & Range, example: "0004" = Argon and "010L" = 10 slpm
	SH40 010C	Standard Configuration #40, 3-10 sccm Nitrogen Equivalent (0° C Reference)
	SH41 030C	Standard Configuration #41, 11-30 sccm Nitrogen Equivalent (0° C Reference)
	SH42 092C	Standard Configuration #42, 31-92 sccm Nitrogen Equivalent (0° C Reference)
	SH43 280C	Standard Configuration #43,93-280 sccm Nitrogen Equivalent (0° C Reference)
	SH44 860C	Standard Configuration #44, 281-860 sccm Nitrogen Equivalent (0° C Reference)
	SH45 2.6L	Standard Configuration #45, 861-2600 sccm Nitrogen Equivalent (0° C Reference)
	SH46 7.2L	Standard Configuration #46, 2601-7200 sccm Nitrogen Equivalent (0° C Reference)
	SH47 015L	Standard Configuration #47, 7201-15000 sccm Nitrogen Equivalent (0° C Reference)
	SH48 030L	Standard Configuration #48, 15001-30000 sccm Nitrogen Equivalent (0° C Reference)
	SH49 040L	Standard Configuration #48, 30001-50000 sccm Nitrogen Equivalent (0° C Reference)
SH50 050L	Standard Configuration #50, 40001-55000 sccm Nitrogen Equivalent (0° C Reference)	
VI. Fitting	VX	1/4" VCR
VII. Downstream Condition	A	Atmosphere
	V	Vacuum
	P	Positive Pressure
VIII. External Seals, Valve Seat	S	Seal Metal / Seat Metal (316 SS)

Code Description	Code Option	Option Description	
IX. Communications / Connector	P0	Profibus / Analog (Input 0 - 20 mA; Output 0 - 20 mA); 9-Pin Female D conn. / 15-Pin Male D conn.	
	P4	Profibus / Analog (Input 4 - 20 mA; Output 4 - 20 mA); 9-Pin Female D conn. / 15-Pin Male D conn.	
	P5	Profibus / Analog (Input 0 - 5 V; Output 0 - 5 V); 9-Pin Female D conn. / 15-Pin Male D conn.	
	S0	RS485 (S-Protocol)/Analog (Input 0 - 20 mA; Output 0 - 20 mA); 15-Pin Male D (Brooks® Protocol)	
	S1	RS485: (S-Protocol)/Analog (Input 0 - 10 V; Output 0 - 10 V); 15-Pin Male D (Brooks® Protocol)	
	S4	RS485 (S-Protocol)/Analog (Input 4 - 20 mA; Output 4 - 20 mA); 15-Pin Male D (Brooks® Protocol)	
	S5	RS485: (S-Protocol)/Analog (Input 0 - 5 V; Output 0 - 5 V)15-Pin Male D (Brooks® Protocol)	
	L0	RS485 (L-Protocol)/Analog (Input 0 - 20 mA; Output 0 - 20 mA); 15-Pin Male D (Celerity®/Legacy Protocol)	
	L1	RS485 (L-Protocol)/Analog (Input 0 - 10 V; Output 0 - 10 V); 15-Pin Male D (Celerity®/Legacy Protocol)	
	L4	RS485 (L-Protocol)/Analog (Input 4 - 20 mA; Output 4 - 20 mA); 15-Pin Male D (Celerity®/Legacy Protocol)	
	L5	RS485 (L-Protocol)/Analog (Input 0 - 5 V; Output 0 - 5 V); 15-Pin Male D (Celerity®/Legacy Protocol)	
	DeviceNet Standard Configuration Parameters		
	I/O	Connector	Power On State
			Full Scale Setting
			Full Scale Setting
			Full Scale Setting
			Poll I/O Instance Producer
			Poll I/O Instance Consumer
			Poll I/O State Transition
		External Baud Rate	
D0	DeviceNet 5Pin Micro	Idle	
D1	DeviceNet 5Pin Micro	Idle	
D2	DeviceNet 5Pin Micro	Idle	
D3	DeviceNet 5Pin Micro	Idle	
D4	DeviceNet 5Pin Micro	Executing	
D5	DeviceNet 5Pin Micro	Idle	
D7	DeviceNet 5Pin Micro	Idle	
D8	DeviceNet 5Pin Micro	Idle	
D9	DeviceNet 5Pin Micro	Executing	
DA	DeviceNet 5Pin Micro	Idle	
DB	DeviceNet 5Pin Micro	Idle	
DC	DeviceNet 5Pin Micro	Idle	
DD	DeviceNet 5Pin Micro	Executing	
DE	DeviceNet 5Pin Micro	Executing	
DX	DeviceNet 5Pin Micro	To be defined by CSR	
X. Customer Special Request	XXXX	Customer Special Request Number	
XI. Auto Shut Off	A	Auto Shut-Off (Included)	
	X	Auto Shut-Off (Not Included)	
XII. Auto Zero	X	Auto Zero (Not Included)	
XIII. Reference Temperature	00C	0 °C Reference	
	15C	15 °C Reference	
	20C	20 °C Reference	
	70F	21.1 °C Reference / 70 °F Reference	

Brooks is committed to assuring all of our customers receive the optimal solution for their application, along with outstanding service and support to back it up. We operate first class repair facilities located around the world to provide rapid response and support. Each location utilizes primary standard calibration equipment to ensure accuracy and reliability for repairs and recalibration and is certified by our local Weights and Measures Authorities and traceable to the relevant International Standards.

Visit [www.BrooksInstrument.com](http://www.BrooksInstrument.com) to locate the service location nearest to you.

### START-UP SERVICE AND IN-SITU CALIBRATION

Brooks Instrument can provide start-up service prior to operation when required. For some process applications, where ISO-9001 Quality Certification is important, it is mandatory to verify and/or (re)calibrate the products periodically. In many cases this service can be provided under in-situ conditions, and the results will be traceable to the relevant international quality standards.

### SEMINARS AND TRAINING

Brooks Instrument can provide customer seminars and dedicated training to engineers, end users, and maintenance persons. Please contact your nearest sales representative for more details. Due to Brooks Instrument's commitment to continuous improvement of our products, all specifications are subject to change without notice.



### TRADEMARKS

Brooks .....Brooks Instrument, LLC

All other trademarks are the property of their respective owners.

Data-Sheet-GF80-GF81-EN/2024-12

**Contech**

Av. Dr. Lino de Moraes Leme, 1.094  
Vila Paulista – São Paulo/SP – 04360-000.  
+55 11 5035-0920  
Atendimento@contechind.com.br

[www.contechind.com.br](http://www.contechind.com.br)