

# GF120xHT Series

## Ultra-High Purity, High-Temperature Digital Mass Flow Controllers & Meters

GF120xHT high-temperature mass flow controllers and meters are designed to control and measure the mass flow rate of vapor from liquid or solid precursors to support the growing usage of these precursors in semiconductor processes.

The flow module is designed to withstand operating environments of up to 150°C. To support this temperature range, the electronics are remotely connected to the rest of the device in a lower temperature location (max 50°C). The remote electronics can be DIN mounted with a choice of three different interconnecting cable lengths - 3ft, 8ft, and 16.5ft standard. To support all user needs, the GF120xHT flow module has been designed with a low profile. For ease of integration, the low profile allows this product to be installed in new process applications or as an upgrade for older generation Brooks 9861 Series applications.



### Features

### Benefits

High-temperature Applications	Ability to support applications up to 150°C for liquid precursor vapor delivery.
Service Port and User-Friendly Interface Provide Access to Advanced Diagnostics	Convenient interface to diagnostics for maximum uptime. Ensures device is operating within user specified limits for high yield and maximum uptime.
Corrosion Resistant Hastelloy Sensor	Provides unmatched long-term sensor stability ensuring maximum yield and throughput.
Calibrated at Customer Process Conditions	Calibrated at customer operating temperature and pressure to ensure optimal operation.

# Product Specifications

## GF120xHT

### Performance<sup>1,2</sup>

Full Scale Flow Range <sup>3</sup>	50 sccm to 5 slm
Flow Accuracy	±1% S.P. >35-100%, ±0.35% F.S. 2-35%
Repeatability & Reproducibility	5-100% = ±0.15% of S.P., 2-5% = ±0.015% of F.S.
Linearity	±0.5% F.S. (included in accuracy)
Response Time (Setting Time) Normally Closed Valve	< 1 sec
Control Range	2-100% (Normally Closed Valve)
Valve Shut Down (N.C. Valve)	<1% of F.S.
Zero Stability	< ± 0.5% F.S. per year
Temperature Coefficient <sup>4</sup>	Span: 0.05% F.S. per °C, Zero: 0.005% F.S. per °C

### Ratings

Operating Temperature Range <sup>5</sup>	45-150°C
Differential Pressure Range	33-860 sccm = 7-45 psid, 861- 5000 sccm = 10-45 psid
Maximum Operating Pressure	500 psia max
Proof Pressure	700 psia max
Design Pressure	800 psia max
Burst Pressure	2500 psia max
Leak Integrity (External)	1x10 <sup>-10</sup> atm. cc/sec He

### Mechanical

Valve Type	Normally Closed (Standard) Meter (No Valve)
Wetted Materials	SEMI F20 UHP Compliant, 316L VIM/VAR, Hastelloy C-22, 316L Stainless Steel, 304 Stainless Steel, KM-45
Surface Finish	5µ inch Ra

### Diagnostics & Display

Status Lights	Analog/RS485/DNET: MFC Health, Network Status ECAT: Run, Error, Power, Network Status
Alarms	Analog/RS485/DNET: Control Valve Output, Network Interruption ECAT: Control Valve Output, Network Interruption, Temperature High/Low, Pressure High/Low, Power Surge/Sag
Display Type <sup>6</sup>	Top Mount Integrated LCD
Viewing Angle / Viewing Distance <sup>6</sup>	Analog/RS485/DNET: Fixed/10 feet, ECAT: Rotatable/10 feet
Units Displayed / Resolution	Flow (%), Temp. (°C), Pressure (psia, kPa) / 0.1 (unit)

### Electrical

Electrical Connection	RS485/Analog via 9-Pin "D" connector, DeviceNet™ via 5-Pin "M12" connector, EtherCAT Power via 5-pin M8 Connector, EtherCAT via RJ45 jacks
Digital Communication	RS485+ (model specific), DeviceNet (model specific), EtherCAT (model specific)
Diagnostics/Service Port	RS485 via 2.5mm jack or micro-USB dependent on model
Power Supply/Consumption	DeviceNet: 550mA max. @ +11-25 Vdc., 300mA max. @ 24Vdc RS485/Analog: 6 Watts max @ +15Vdc. (+10%) or +24 Vdc (±10%) EtherCAT: 330mA max. @ 18-30 Vdc, 300 mA max. @ 24 Vdc (under typical operating conditions)

### Compliance

EMC	Analog/RS485/DNET: EC Directive 2004/108/EC CE: EN61326: 2006 (FCC Part 15 & Canada IC-subset of CE testing) EtherCAT: EMC Directive 2014/30/EU Evaluation Standard EN61326-1:2013
Environmental Compliance	RoHS Directive (2011/65/EU & 2015/863/EU) REACH Directive EC 1907/2006

<sup>1</sup>Based on factory N<sub>2</sub> calibration, reference conditions are as per SEMI E12 specification, standard pressure and temperature, consult applications for accuracy and response for analog communications.

<sup>2</sup>Devices are sized per application specific conditions provided by the customer. Operating temperature and pressure provided by the customer are used in device calibration. Devices will be calibrated between 150T and 1500T inlet pressures.

<sup>3</sup>Consult factory for additional flow options.

<sup>4</sup>The temperature coefficient specification is applicable ±10°C from the calibration temperature listed on the product label and CoC.

<sup>5</sup>Operating temperature range is defined for the flow module, the remote electronics must be mounted at a low temperature location (50°C max).

<sup>6</sup>Applicable for those units with displays.

## GF120xHT Series - Remote Electronics

DEVICENET

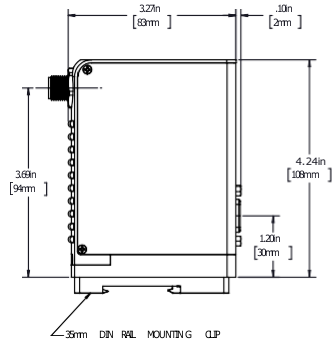
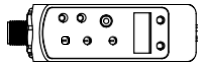

ETHERCAT

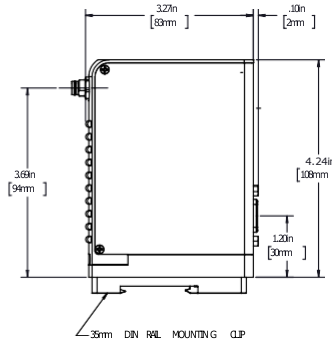
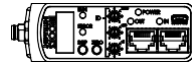

ANALOG/RS485  
MODEL CODE OPTION: G1/GX

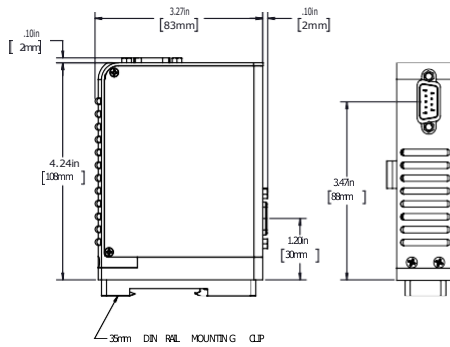
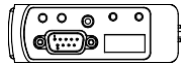

ANALOG/RS485 with VTP  
MODEL CODE OPTION: SX

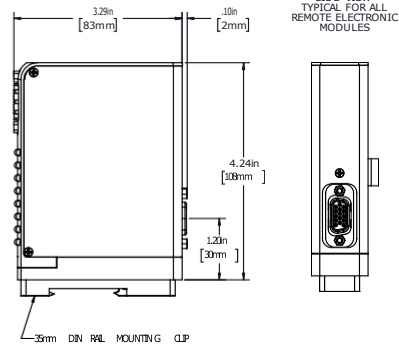
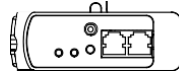

## GF120xHT Series - Flow Module Configurations

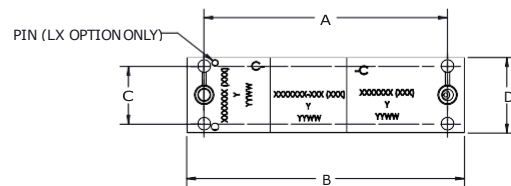
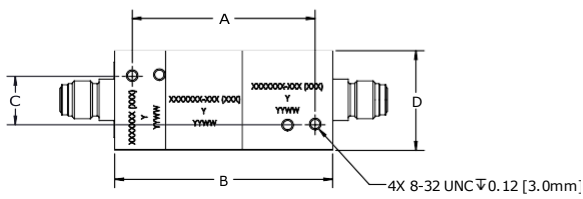
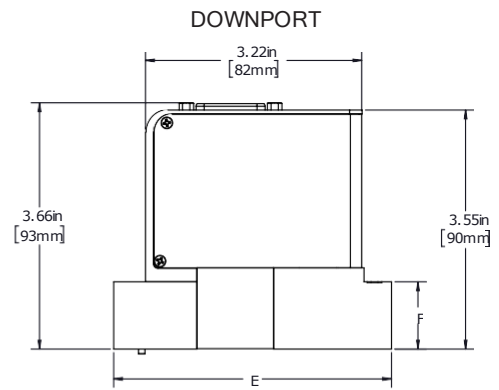
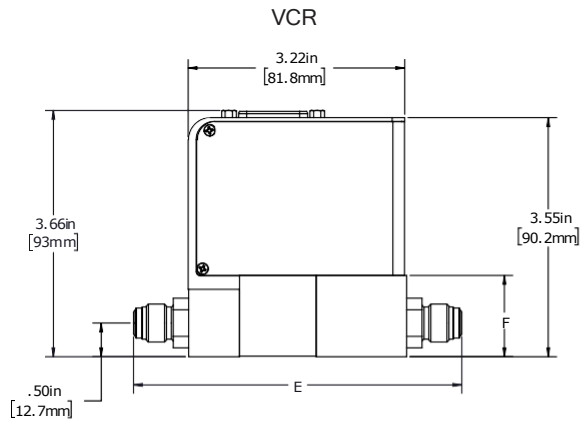

Fitting Option Code	Dim A	Dim B	Dim C	Dim D	Dim E	Dim F
VX	69mm [2.72in]	82mm [3.24in]	18mm [0.72in]	38mm [1.48in]	124mm [4.88in]	31mm [1.21in]
VS	69mm [2.72in]	82mm [3.24in]	18mm [0.72in]	28mm [1.12in]	124mm [4.88in]	31mm [1.21in]
CX	92mm [3.62in]	105mm [4.13in]	22mm [0.86in]	28mm [1.12in]	105mm [4.13in]	25mm [1.00in]
WX	92mm [3.62in]	105mm [4.13in]	22mm [0.86in]	28mm [1.12in]	105mm [4.13in]	25mm [1.00in]
BX	92mm [3.62in]	105mm [4.13in]	30mm [1.18in]	38mm [1.48in]	105mm [4.13in]	25mm [1.00in]
LX	92mm [3.62in]	105mm [4.13in]	22mm [0.86in]	28mm [1.12in]	105mm [4.13in]	25mm [1.00in]

# Electrical Interface Options

## Base I/O Options

## Adapter Cables with Base I/O Option

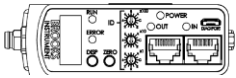

Description: Industry Standard EtherCAT interface

EtherCAT diagnostic port communication via micro-USB

### Model Code Option: E0

Pin	Description
1	+24V
3	Power Common

### Model Code Option: G1

Pin	Description
1	Valve Control
2	Output (0-5 Vdc)
3	+15 Vdc +24 Vdc
4	Pwr Com NC
5	-15 Vdc Pwr Com
6	Setpoint (0-5 Vdc)
7	Signal Common
8	RS-485 (DX+)
9	RS-485 (DX-)

### Model Code Option: GX

Pin	Description
1	Valve Control
2	Output (0-5 Vdc)
3	+15 Vdc +24 Vdc
4	Pwr Com NC
5	-15 Vdc Pwr Com
6	Setpoint (0-5 Vdc)
7	Signal Common
8	RS-485 (DX+)
9	RS-485 (DX-)

### Model Code Option: DX

Pin	Description
1	Drain
2	V+ (11-25 Vdc)
3	V-
4	CAN-H
5	CAN-L

### Model Code Option: SX

Pin	Description
1	Valve Control
2	Output (0-5 Vdc)
3	+15 Vdc +24 Vdc
4	Pwr Com NC
5	-15 Vdc Pwr Com
6	Setpoint (0-5 Vdc)
7	Signal Common
8	Signal Common
9	Valve Test Point
RJ11 Pin	Description
3	RS-485 (DX-)
4	RS-485 (DX+)

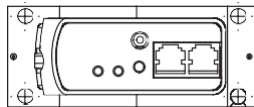

Description: Industry standard Analog 9-Pin Sub D connector and dual RJ11 RS485 ports

Above Base I/O options include:  
Diagnostic port communication RS485 via 2.5mm jack

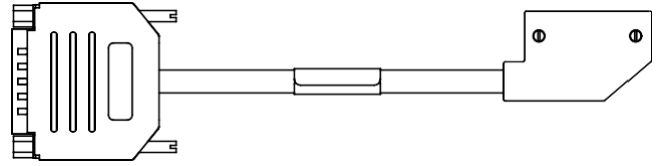

A range of low profile adapter cables have been developed to support replacing older generation MFC's with different pinout configurations. The base MFC will be either a G1, GX or SX configuration.

### Model Code Option: UX

Pin	Description
9	Valve Off
6	Output (0-5 Vdc)
4	+15 Vdc +24 Vdc
7	Pwr Com NC
11	-15 Vdc Pwr Com
15	Setpoint (0-5 Vdc)
1,13,14	Signal Common
2	Zero Alarm
12	Valve Test Point
8	Case Ground
3,5,10	No Connection

Description: SX base I/O with 7003550 adapter

### Model Code Option: BX

Pin	Description
12	Valve Override
2	Output (0-5 Vdc)
5	+15 Vdc +24 Vdc
9	Pwr Com NC
6	-15 Vdc Pwr Com
8	Setpoint (0-5 Vdc)
1,10	Signal Common
3,4,7,11	No Connection
13,14,15	No Connection

Description: G1 base I/O with 7003590 adapter

### Model Code Option: FX/JX

Pin	Description
1	Valve Control
2	Output (0-5 Vdc)
3	+15 Vdc +24 Vdc
4	Pwr Com NC
5	-15 Vdc Pwr Com
6	Setpoint (0-5 Vdc)
7	Signal Common
8	Signal Common
9	Valve Test Point

Description: SX base I/O with 7003069 (FX)/7001814 (JX) adapter

### Model Code Option: KX

Pin	Description
3	Valve Control
2	Output (0-5 Vdc)
7	+15 Vdc +24 Vdc
5	Pwr Com NC
6	-15 Vdc Pwr Com
8	Setpoint (0-5 Vdc)
11,12	Signal Common
15	Case Ground
1,4,9,10,13,14	No Connection

Description: G1 base I/O with 7003298 adapter

### Model Code Option: QX/HX/IX

Pin	Description
J	Valve Off
3	Output (0-5 Vdc)
4	+15 Vdc +24 Vdc
2	Pwr Com NC
F	-15 Vdc Pwr Com
A	Setpoint (0-5 Vdc)
B,C,10	Signal Common
1	Case Ground
5,6,8,9	Not Connected
I,D,E,H	Not Connected
7,G	Key Way

Description: SX, G1, or GX base respectively I/O with 097B393ZZZ adapter for compatibility

Note: Pin No 10 can be disconnected from Signal Common by removing jumper P1 on the 097B393ZZZ adapter.

### Model Code Option: EX

Pin	Description	
J	Valve Off	
3	Output (0-5 Vdc)	
4	+15 Vdc +24 Vdc	
2	Pwr Com NC	
F	-15 Vdc Pwr Com	
A	Setpoint (0-5 Vdc)	
B,C,10	Signal Common	
1	Case Ground	
5,6,8,9	Not Connected	
I,D,E,H	Not Connected	
7,G	Key Way	
J2	J3	
3	3	RS-485 (DX-)
4	4	RS-485 (DX+)

Description: GX base I/O with 7003083 adapter

Other adapter options are available for the GF Series.  
Please contact Customer Service for more information.

# Model Code

Code Description	CodeOption	Option Description										
I. Base Model Code	GF	Ultra High Purity Digital Mass Flow Controller and Meter										
II. Package / Finish Specifications	120	Flow range 50 SCCM - 5 SLPM N <sub>2</sub> Eq										
III. Configurability	X	Gas Code and Range Required										
IV. Special Application	HT	High Temperature (up to 150°C)										
V. Valve Configuration	C	Normally Closed Valve										
	M	Meter (No Valve)										
VI. Gas Range	XXXX XXXX	Specific Gas Code & Range, i.e. "0004" = Argon and "001L" = 1 SLPM										
VII. Fitting	VX	1-1/2" body width, 124mm 1/4" VCR male										
	VS	1-1/8" body width, 124mm 1/4" VCR male										
	CX	1-1/8" body width, 92mm C Seal										
	WX	1-1/8" body width, 92mm W Seal										
	BX	1-1/2" body width, 92mm W Seal										
	LX	1-1/8" body width, 92mm C Seal w/Poke Yoke										
VIII. Downstream Condition	A	Atmosphere										
	V	Vacuum										
IX. Sensor	O	Default Sensor Orientation										
X. Communications/Connector	E0	EtherCAT Communication										
	BX	Cable adapter to 15 pin D adapts G1 base										
	EX	Adapter to Card Edge (w/out VTP), RS485 through RJ11 jacks adapts GX base										
	FX	Cable adapter with 9 pins STEC pin-out & jack screws (w/VTP) adapts SX base										
	GX	9-Pin D with RS485; display and overlay 180° orientation										
	G1	9-Pin D with RS485										
	HX	Adapter to Cardedge adapts to G1 base										
	IX	Adapter to Cardedge adapts to GX base										
	JX	Cable adapter with 9 pin STEC pin-out & jack screws (w/VTP) adapts SX base										
	KX	Cable adapter to MKS 15-Pin D; adapts G1 base										
	QX	Adapter to Cardedge (w/out VTP) adapts to SX base										
	SX	9 pin D with STEC pin-out (w/VTP)										
	UX	Cable adapter to 15 pin D (w/VTP) adapts SX base										
		<b>Option</b>	<b>I/O</b>	<b>Connector</b>	<b>Power On State</b>	<b>Full Scale Setting</b>	<b>Full Scale Setting</b>	<b>Full Scale Setting</b>	<b>Poll I/O Instance Producer</b>	<b>Poll I/O Instance Consumer</b>	<b>Poll I/O State Transition</b>	<b>External Baud Rate</b>
		D0	DeviceNet	5 Pin Micro	Idle	Count	Integer	6000h	2	7	Executing	500KB
		D1	DeviceNet	5 Pin Micro	Idle	Count	Integer	6000h	21	7	Executing	500KB
		D2	DeviceNet	5 Pin Micro	Idle	SCCM	Float	7FFFh	13	19	Executing	500KB
		D3	DeviceNet	5 Pin Micro	Idle	Count	Integer	6000h	22	7	Executing	500KB
		D4	DeviceNet	5 Pin Micro	Executing	Count	Integer	6000h	22	8	Executing	500KB
		D5	DeviceNet	5 Pin Micro	Idle	Count	Integer	6000h	6	8	Executing	500KB
		D6	DeviceNet	5 Pin Micro	Idle	Count	Integer	7FFFh	3	7	Executing	500KB
		D7	DeviceNet	5 Pin Micro	Idle	Count	Integer	7FFFh	6	8	Executing	500KB
		D8	DeviceNet	5 Pin Micro	Idle	Count	Integer	6000h	3	7	Executing	500KB
		D9	DeviceNet	5 Pin Micro	Executing	Count	Integer	6000h	2	7	Executing	500KB
		DA	DeviceNet	5 Pin Micro	Idle	Count	Integer	7FFFh	22	7	Executing	500KB
		DB	DeviceNet	5 Pin Micro	Idle	Count	Integer	6000h	22	8	Executing	500KB
	DC	DeviceNet	5 Pin Micro	Idle	Count	Integer	7FFFh	3	7	Idle	500KB	
	DD	DeviceNet	5 Pin Micro	Executing	Count	Integer	7FFFh	22	8	Executing	500KB	
	DE	DeviceNet	5 Pin Micro	Executing	SCCM	Float	6000h	15	19	Executing	500KB	
	DX	DeviceNet	5 Pin Micro	To be defined by Customer Special Request								

# Model Code

XI. Customer Special Request	XXXX	Customer Special Request Number; required with "DX" Conn. Option to define DNet settings
XII. Auto Shut-Off	A	Auto Shut-Off (Included)
	X	Auto Shut-Off (Not Included) (Must be selected for meter)
XIII. Auto Zero	X	Auto Zero (Not Included)
XIV. Reference Temperature	000	0°C Reference Calibration (Standard) - Default Setting
XV. Operating Temperature	XXX	Operating Temperature Value in five degree intervals from 45°C to 150°C 45°C = 045, 100°C = 100, 150°C = 150
XVI. Cable Length	X	3ft
	M	8ft
	L	16.5ft

Sample GF120xHT Model Code

I	II	III	IV	V		VI		VII	VIII	IX	X		XI	XII	XIII		XIV		XV	XVI
GF	120	X	HT	M	-	0013100C	-	VX	A	O	GX	-	XXXX	X	X	-	000	-	100	M

Brooks is committed to assuring all of our customers receive the ideal mass flow controllers for their application, along with outstanding service and support to back it up. We operate first class repair facilities located around the world to provide rapid response and support. Each location utilizes primary standard calibration equipment to ensure accuracy and reliability for repairs and recalibration and is certified by our local Weights and Measures Authorities and traceable to the relevant International Standards.

Visit [www.BrooksInstrument.com](http://www.BrooksInstrument.com) to locate the service location nearest to you.

### START-UP SERVICE AND IN-SITU CALIBRATION

Brooks Instrument can provide start-up service prior to operation when required. For some process applications, where ISO-9001 Quality Certification is important, it is mandatory to verify and/or (re)calibrate the products periodically. In many cases this service can be provided under in-situ conditions, and the results will be traceable to the relevant international quality standards.

### SEMINARS AND TRAINING

Brooks Instrument can provide customer seminars and dedicated training to engineers, end users, and maintenance persons. Please contact your nearest sales representative for more details. Due to Brooks Instrument's commitment to continuous improvement of our products, all specifications are subject to change without notice.



### TRADEMARKS

Brooks.....Brooks Instrument, LLC

All other trademarks are the property of their respective owners.

Data-Sheet-GF120XHT-EN/2024-01



Av. Dr. Lino de Moraes Leme, 1.094  
Vila Paulista – São Paulo/SP - 04360-000.

+55 11 5035-0920

Atendimento@contechind.com.br

[www.contechind.com.br](http://www.contechind.com.br)