

GF100 Series - Analog, DeviceNet

Metal Sealed, High-Purity/Ultra-High Purity Thermal Mass Flow Controllers & Meters for Gases

Designed for semiconductor, MOCVD, and other gas flow control applications that require a high-purity all-metal flow path, the Brooks™ GF100 Series thermal mass flow controllers and meters deliver outstanding performance, reliability, and flexibility. The GF100 Series has been marathon tested to over three times the semiconductor industry standard for reliability, ensuring repeatable low-drift performance over time. An independent diagnostic/service port permits users to troubleshoot or change flow conditions without removing the mass flow controller from service.

The GF100 Series feature set was designed to enable drop-in replacement and upgrade of most brands of metal-seal mass flow controllers, including the former Celerity, UNIT, Tylan, and Mykrolis brands. With the wide range of options and features available, the GF100 Series provides users with a path to simplification and standardization, greatly reducing spares inventory and support costs.



Features

Benefits

| | |
|--|---|
| Corrosion Resistant Hastelloy Sensor | Provides unmatched long-term sensor stability ensuring maximum yield and throughput. |
| Pressure Transient Insensitivity | Reduces crosstalk sensitivity for consistent mass flow delivery and reduces wafer-to-wafer variability. |
| Zero Leak-by Control Valve | Valve shut down (up to $\leq 0.005\%$ of F.S.) to minimize the first wafer effect, improve tool matching, and wafer-to-wafer uniformity. |
| GF120 Safe Delivery System (SDS [®]) | Low pressure drop MFC for the delivery of sub-atmospheric safe delivery system (SDS) gases used in Implant and Etch processes. |
| MultiFlo™ Gas and Range Technology | Enables one MFC to support thousands of gas types and range combinations without removing it from the gas line or compromising on accuracy. |

Product Specifications

| | GF100 | GF120 | GF125 | GF120XSL | GF120XSD |
|---|--|--------|--|---------------------------------------|------------------|
| Performance¹ | | | | | |
| F.S. Flow Ranges | 3 sccm - 55 slm | | | 4 sccm - 25 sccm | >25 sccm - 1 slm |
| Flow Accuracy | ±1% S.P. >35 - 100%, ±0.35% F.S. 2 - 35% | | | | |
| Repeatability & Reproducibility | 5 - 100% = ±0.15% of S.P. 2 - 5% = ±0.015% of F.S. | | | | |
| Linearity | ±0.5% F.S. (included in accuracy) | | | --- | |
| Response Time (Setting Time) N.C. Valve | <1 sec | 700 ms | 300 ms (3 - 860 sccm) 400 ms (861 - 7200 sccm) 500 ms (7201 - 30000 sccm) < 700 ms (30001 - 55000 sccm) | < 3 sec | |
| N.O. Valve | <1.5 sec | | | --- | |
| Pressure Insensitivity | Not Applicable | | <5% S.P. up to 5 psi/sec upstream pressure spike | Not Applicable | |
| Control Range | 2 - 100% (Normally Closed Valve) 3 - 100% (Normally Open Valve) | | | 2 - 100% (Normally Closed Valve) | |
| MultiFlo™ | Standard | | | --- | |
| # of Bins | 11 bins | | | --- | |
| Valve Shut Down (N.C. Valve) ^{2,3} | Standard Hastelloy Valve: <1% of F.S. Zero Leak-by Valve: SH40 - SH41 <0.02% F.S. SH42 - SH50 <0.005% F.S. | | | Standard Hastelloy Valve: <1% of F.S. | |
| Valve Shut Down (N.O. Valve) | 2% of F.S. | | | --- | |
| Zero Stability | <±0.5% F.S. per year | | | <±0.6% F.S. per year | |
| Temperature Coefficient | Zero: 0.005% F.S. per °C; Span: 0.05% F.S. per °C | | | | |

Ratings

| | | | | | |
|--|--|--|--------------|---|--|
| Operating Temperature Range | 10 - 50°C | | | | |
| Differential Pressure Range ⁴ | 3 - 860 sccm = 7 - 45 psid 861 - 7200 sccm = 10 - 45 psid 7201 - 55000 sccm = 15 - 45 psid | | | 10 Torr - 30 psid typical For more details consult factory | |
| Maximum Operating Pressure | 500 psia max | | 100 psia max | 500 psia max | |
| Proof Pressure | 700 psia max | | 140 psia max | 700 psia max | |
| Design Pressure | 800 psia max | | 170 psia max | 800 psia max | |
| Burst Pressure | 3000 psia max | | 500 psia max | 3000 psia max | |
| Leak Integrity (External) | 1x10 ⁻¹⁰ atm. cc/sec He | | | | |

Mechanical

| | | | | | |
|------------------|---|--|------------|-----------------|--|
| Valve Type | Normally Closed (Standard or Zero Leak-by) Normally Open Meter (no valve) | | | Normally Closed | |
| Wetted Materials | SEMI F20 HP Compliant, 316L VIM/VAR, Hastelloy C-22, 316L Stainless Steel, 304 Stainless Steel, KM-45, PCTFE (on optional Zero Leak-by Valve) | | | | |
| Surface Finish | 10μ inch Ra | | 5μ inch Ra | | |

Display & Diagnostics

| | | | | | |
|----------------------------------|---|--|--|--|--|
| Status Lights | MFC Health, Network Status | | | | |
| Alarms | Control Valve Output, Network Interruption | | | | |
| Display Type | Top Mount Integrated LCD | | | | |
| Viewing Angle / Viewing Distance | Fixed / 10 feet | | | | |
| Units Displayed / Resolution | Flow (%), Temp. (°C), Pressure (psia, kPa) / 0.1 (unit) | | | | |

NOTE: Consult Brooks Applications Engineering for accuracy and response for analog communications.

NOTE: See the following Safe Delivery System (SDS) section for optional detailed specifications.

¹ Based on factory N₂ calibration.

² The Zero Leak-by Valve can be ordered via the Customer Special Request process.

³ Valve Shut Down full scale is defined as the MultiFlo™ full scale bin range or the full scale range of the factory configured gas & range devices.

⁴ Argon gas applications require an additional 10 psid differential pressure. Devices greater than 30L require a 45 psia minimum inlet pressure. Low vapor pressure gases require an inlet pressure of > 100 Torr, with vacuum on outlet (example SiCl₄). Contact Brooks Technical Support for more information.

Product Specifications

| | GF100 | GF120 | GF125 | GF120XSL | GF120XSD |
|----------------------------|--|-------|-------|----------|----------|
| Electrical | | | | | |
| Electrical Connection | RS485 / Analog via 9-Pin "D" connector, DeviceNet™ via 5-Pin "M12" connector | | | | |
| Digital Communication | RS485+ (model specific), DeviceNet (model specific), RS485 Diagnostic Port (all models) | | | | |
| Diagnostics / Service Port | RS485 via 2.5mm jack | | | | |
| Power Supply / Consumption | DeviceNet: 545 mA max. @ +11 - 25 Vdc., 250 mA max. @ 24 Vdc RS485 / Analog: 6 Watts max @ ±15 Vdc. (±10%) or + 24 Vdc (±10%) | | | | |
| Compliance | | | | | |
| EMC | EC Directive 2004/108/EC CE: EN61326: 2006 (FCC Part 15 & Canada IC-subset of CE testing) RoHS Directive (2011/65/EU) REACH Directive EC 1907/2006 | | | | |
| Environmental Compliance | | | | | |

Product Specifications

| | GF101 | GF121 | GF126 |
|--|---|-----------------------------------|----------|
| Performance¹ | | | |
| F.S. Flow Range | 55 slm - 300 slm | | |
| Flow Accuracy | ±1% S.P. >35 - 100%; ±0.35% F.S. 2 - 35% | | |
| Repeatability & Reproducibility | <±0.15% S.P. | | |
| Response Time (Setting Time) N.C. Valve | <1 sec | | |
| Pressure Insensitivity | Not Applicable | Ability to measure inlet pressure | |
| Control Range | 5 - 100% (N.C. Valve) | | |
| MultiFlo™ | Standard | | |
| # of Bins | 4 bins | | |
| Valve Shut Down (N.C. Valve) ² | <2% of F.S. @ 30 N ₂ psig/atm out | | |
| Zero Stability | <±0.5% F.S. per year | | |
| Temperature Coefficient | Zero: 0.005% F.S. per °C; Span: 0.05% F.S. per °C | | |
| Ratings | | | |
| Operating Temperature Range | 10 - 50°C | | |
| Differential Pressure Range | 30 - 90 psid | | |
| Maximum Operating Pressure | Controller: 75 psig Meter: 150 psig | | |
| Proof Pressure | 700 psia | 140 psia | |
| Design Pressure | 800 psia | 700 psia | 170 psia |
| Burst Pressure | 3000 psia | | 500 psia |
| Leak Integrity (External) | 1x10 ⁻¹⁰ atm. cc/sec He | | |
| Mechanical | | | |
| Valve Type | Normally Closed Meter (no valve) | | |
| Wetted Materials | SEMI F20 HP Compliant, 316L VIM/VAR, Hastelloy C-22, 316L Stainless Steel, 304 Stainless Steel, KM-45 | | |
| Surface Finish | 10μ inch Ra | 5μ inch Ra | |
| Diagnostics & Display | | | |
| Status Lights | MFC Health, Network Status | | |
| Alarms | Control Valve Output, Network Interruption | | |
| Display Type | Top Mount Integrated LCD | | |
| Viewing Angle / Viewing Distance | Fixed / 10 feet | | |
| Units Displayed / Resolution | Flow (%), Temp. (°C), Pressure (psia, kPa) / 0.1 (unit) | | |
| Electrical | | | |
| Electrical Connection | RS485 / Analog via 9-Pin "D" connector, DeviceNet™ via 5-Pin "M12" connector | | |
| Digital Communication | RS485+ (model specific), DeviceNet (model specific), RS485 Diagnostic Port (all models) | | |
| Diagnostic / Service Port | RS485 via 2.5mm jack | | |
| Power Supply / Consumption | DeviceNet: 545 mA max. @ +11-25 Vdc., 250 mA max. @ 24 Vdc (Under typical operating conditions) RS485 / Analog: 6 Watts max @ +15 Vdc. (+10%) (Under typical operating conditions) | | |
| Compliance | | | |
| EMC | EC Directive 2004/108/EC CE: EN61326: 2006 (FCC Part 15 & Canada IC-subset of CE testing) | | |
| Environmental Compliance | RoHS Directive (2011/65/EU) Reach Directive EC (1907/2006) | | |

¹ Based on factory N₂ calibration.

² Valve Shut Down full scale is defined as the MultiFlo™ full scale bin range or the full scale flow range of the factory configured gas & range devices.

Product Dimensions

GF100 / GF120 / GF125 Downport Configurations

Electrical Connector
DX / BB Specific Dimensions

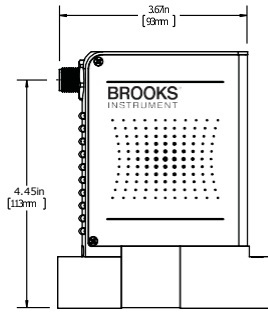

Electrical Connector
G1 / GX / TX Specific Dimensions

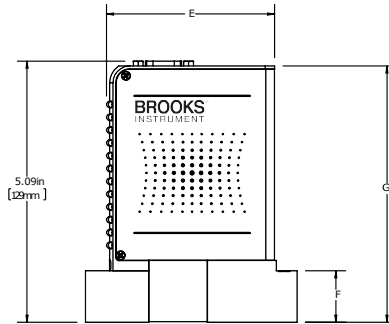

Electrical Connector
SX Specific Dimensions

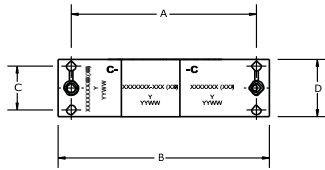
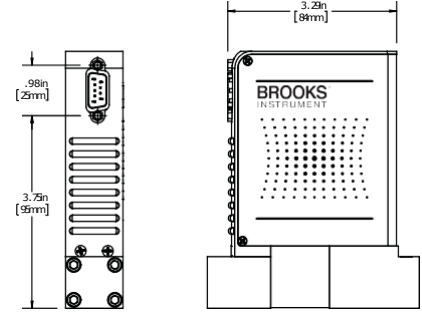

| Fitting Option Code | Seal Type | Dim A | Dim B | Dim C | Dim D | Dim E | Dim F | Dim G |
|---------------------|-------------------|-----------------|----------------|-----------------|---------------|---------------|---------------|----------------|
| CX | C-SEAL | 3.62in [92mm] | 4.13in [105mm] | 0.86in [22mm] | 1.12in [28mm] | 3.28in [83mm] | 1.00in [25mm] | 5.00in [127mm] |
| EX | W-SEAL | 3.14in [79.8mm] | 3.66in [93mm] | 1.18in [1.18mm] | 1.48in [38mm] | 2.82in [72mm] | 1.00in [25mm] | 5.00in [127mm] |
| WX | W-SEAL | 3.62in [92mm] | 4.13in [105mm] | 0.86in [22mm] | 1.12in [28mm] | 3.28in [83mm] | 1.00in [25mm] | 5.00in [127mm] |
| DX | C-SEAL | 3.14in [79.8mm] | 3.66in [93mm] | 0.86in [22mm] | 1.12in [28mm] | 2.82in [72mm] | 1.00in [25mm] | 5.00in [127mm] |
| YX | W-SEAL | 3.14in [79.8mm] | 3.66in [93mm] | 0.86in [22mm] | 1.12in [28mm] | 2.82in [72mm] | 1.00in [25mm] | 5.00in [127mm] |
| AX | C-SEAL | 3.62in [92mm] | 4.13in [105mm] | 1.18in [30mm] | 1.48in [38mm] | 3.28in [83mm] | 1.00in [25mm] | 5.00in [127mm] |
| BX | W-SEAL | 3.62in [92mm] | 4.13in [105mm] | 1.18in [30mm] | 1.48in [38mm] | 3.28in [83mm] | 1.00in [25mm] | 5.00in [127mm] |
| LX | C-SEAL | 3.62in [92mm] | 4.13in [105mm] | 0.86in [22mm] | 1.12in [28mm] | 3.28in [83mm] | 1.00in [25mm] | 5.00in [127mm] |
| AS | Large Bore C-SEAL | 3.62in [92mm] | 4.13in [105mm] | 1.18in [30mm] | 1.48in [38mm] | 3.28in [83mm] | 1.00in [25mm] | 5.00in [127mm] |

GF100 / GF120 / GF125 Face Seal Configurations

Electrical Connector
DX / BB Specific Dimensions

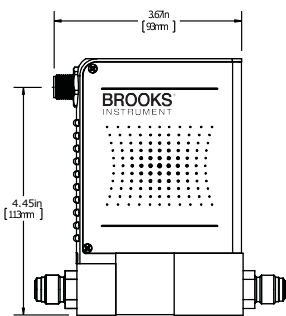

Electrical Connector
G1 / GX / TX Specific Dimensions

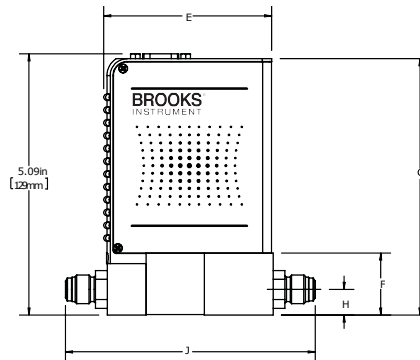

Electrical Connector
SX Specific Dimensions

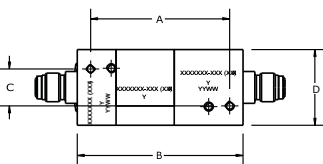
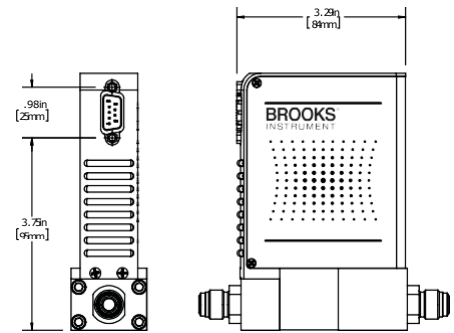

| Fitting Option Code | Seal Type | Dim A | Dim B | Dim C | Dim D | Dim E | Dim F | Dim G | Dim H | Dim J |
|---------------------|-----------|---------------|---------------|---------------|-----------------|---------------|---------------|----------------|---------------|----------------|
| VX | 1/4" VCR | 2.72in [69mm] | 3.24in [82mm] | 0.72in [18mm] | 1.48in [38mm] | 3.28in [83mm] | 1.21in [31mm] | 5.01in [127mm] | 0.50in [13mm] | 4.88in [124mm] |
| VS | 1/4" VCR | 2.72in [69mm] | 3.24in [82mm] | 0.72in [18mm] | 1.12in [28.4mm] | 3.28in [83mm] | 1.21in [31mm] | 5.01in [127mm] | 0.50in [13mm] | 4.88in [124mm] |

GF101 / GF121 / GF126 Downport Configurations

Electrical Connector
DX Specific Dimensions

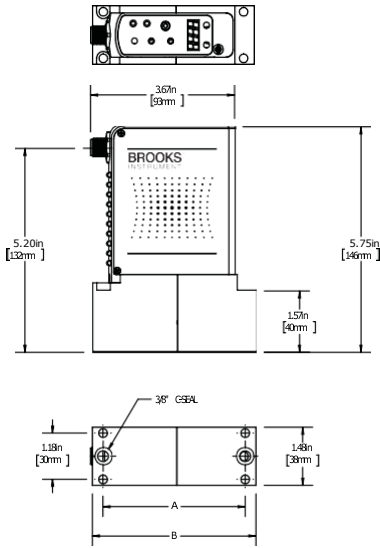

Electrical Connector
G1 / GX Specific Dimensions

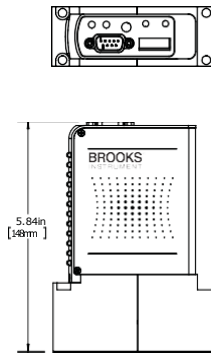

Electrical Connector
SX Specific Dimensions

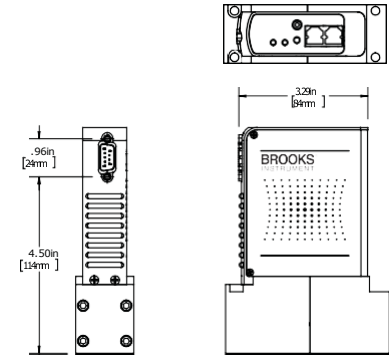

| Fitting Option Code | Seal Type | Dim A | Dim B |
|---------------------|-------------|----------------|----------------|
| C1 | 3/8" C-Seal | 3.62in [92mm] | 4.17in [106mm] |
| C2 | 3/8" C-Seal | 4.49in [114mm] | 5.00in [127mm] |

GF101 / GF121 / GF126 Face Seal Configurations

Electrical Connector
G1 / GX Specific Dimensions

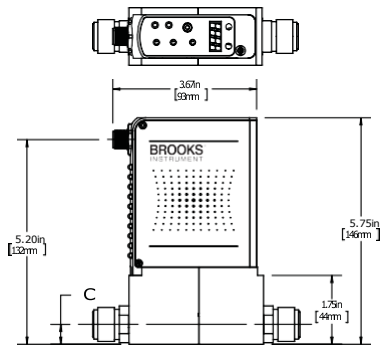

Electrical Connector
DX Specific Dimensions

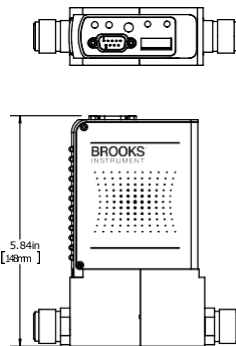

Electrical Connector
SX Specific Dimensions

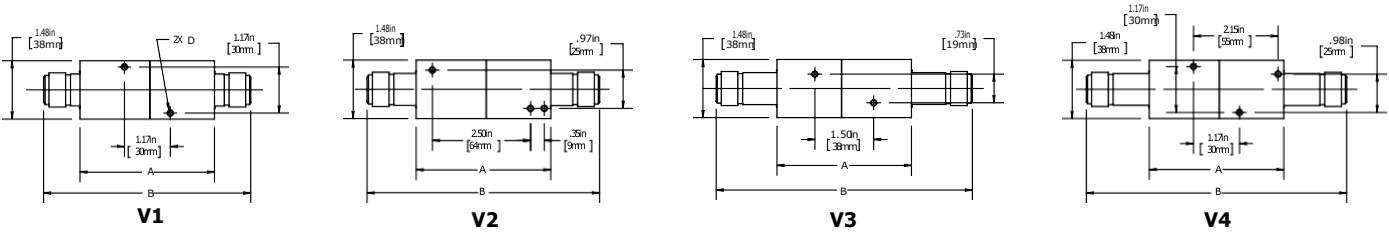
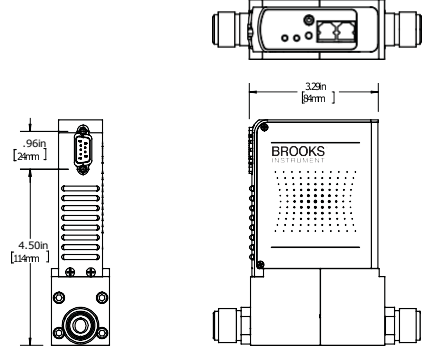

| Fitting Option Code | Seal Type | Dim A | Dim B | Dim C | Dim D |
|---------------------|-----------|------------------|---------------|-----------------|--------------------------------|
| V1 | 1/2" VCR | 5.28in [134.2mm] | 3.43in [87mm] | 0.50in [12.7mm] | M4 X 0.7 X 0.23in [5.8mm] DEEP |
| V2 | 1/2" VCR | 5.92in [150.4mm] | 3.43in [87mm] | 0.62in [15.5mm] | M4 X 0.7 X 0.23in [5.8mm] DEEP |
| V3 | 1/2" VCR | 6.54in [166mm] | 3.43in [87mm] | 0.49in [12.4mm] | M4 X 0.7 X 0.23in [5.8mm] DEEP |
| V4 | 1/2" VCR | 6.64in [168.6mm] | 3.43in [87mm] | 0.63in [16.0mm] | M4 X 0.7 X 0.23in [5.8mm] DEEP |

Product Connections

Base I/O Options

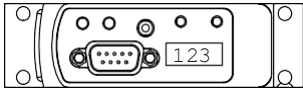

Description: Industry standard Analog / RS485 interface

Model Code Option: G1

| Pin | Description |
|-----|----------------------|
| 1 | Valve Control |
| 2 | Output (0 - 5 Vdc) |
| 3 | +15 Vdc +24 Vdc |
| 4 | Pwr Com NC |
| 5 | -15 Vdc Pwr Com |
| 6 | Setpoint (0 - 5 Vdc) |
| 7 | Signal Common |
| 8 | RS485 (DX+) |
| 9 | RS485 (DX-) |

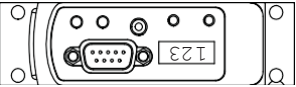

Description: OEM specific Analog / RS485 interface. Display and top plate re-oriented 180°

Model Code Option: GX

| Pin | Description |
|-----|----------------------|
| 1 | Valve Control |
| 2 | Output (0 - 5 Vdc) |
| 3 | +15 Vdc +24 Vdc |
| 4 | Pwr Com NC |
| 5 | -15 Vdc Pwr Com |
| 6 | Setpoint (0 - 5 Vdc) |
| 7 | Signal Common |
| 8 | RS485 (DX+) |
| 9 | RS485 (DX-) |

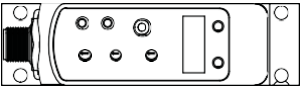

Description: Industry standard ODVA compliant DeviceNet interface

Model Code Option: DX

| Pin | Description |
|-----|------------------|
| 1 | Drain |
| 2 | V+ (11 - 25 Vdc) |
| 3 | V- |
| 4 | CAN-H |
| 5 | CAN-L |

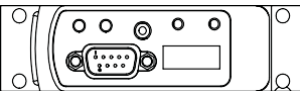

Description: Industry standard Analog only interface

Model Code Option: TX

| Pin | Description |
|-----|----------------------|
| 1 | Valve Control |
| 2 | Output (0 - 5 Vdc) |
| 3 | +15 Vdc +24 Vdc |
| 4 | Pwr Com NC |
| 5 | -15 Vdc Pwr Com |
| 6 | Setpoint (0 - 5 Vdc) |
| 7 | Signal Common |
| 8 | No Connection |
| 9 | No Connection |

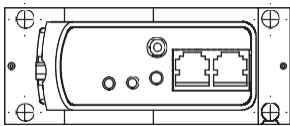

Description: Industry standard Analog 9-Pin Sub D connector and dual RJ11 RS485 ports

Model Code Option: SX

| Pin | Description |
|----------|----------------------|
| 1 | Valve Control |
| 2 | Output (0 - 5 Vdc) |
| 3 | +15 Vdc +24 Vdc |
| 4 | Pwr Com NC |
| 5 | -15 Vdc Pwr Com |
| 6 | Setpoint (0 - 5 Vdc) |
| 7 | Signal Common |
| 8 | Signal Common |
| 9 | Valve Test Point |
| RJ11 Pin | Description |
| 3 | RS485 (DX-) |
| 4 | RS485 (DX+) |

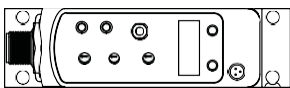

Description: Industry standard ODVA compliant DeviceNet interface, Plus a separate Analog 0-5 Vdc Connector

Model Code Option: BB

| Pin | Description |
|------------|------------------|
| 1 | Drain |
| 2 | V+ (11 - 25 Vdc) |
| 3 | V- |
| 4 | CAN-H |
| 5 | CAN-L |
| HIROSE Pin | Description |
| 1 | Flow Out |
| 2 | AGND |
| 3 | GPIO CAP0 |
| 4 | GHD Earth |

All Base I/O options include:
Diagnostic port communication RS485 via 2.5mm jack

Adapter Cables with Base I/O Option

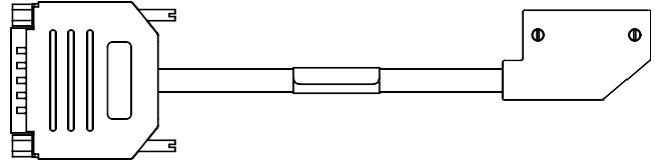

A range of low profile adapter cables have been developed to support replacing older generation MFCs with different pinout configurations. The base MFC will be either a G1, TX or SX configuration, depending on the product being replaced.

Model Code Option: UX

| Pin | Description |
|---------|----------------------|
| 9 | Valve Off |
| 6 | Output (0 - 5 Vdc) |
| 4 | +15 Vdc +24 Vdc |
| 7 | Pwr Com NC |
| 11 | -15 Vdc Pwr Com |
| 15 | Setpoint (0 - 5 Vdc) |
| 1,13,14 | Signal Common |
| 2 | Zero Alarm |
| 12 | Valve Test Point |
| 8 | Case Ground |
| 3,5,10 | No Connection |

Description: SX base I/O with 7003550 adapter for compatibility with Unit UDU15

Model Code Option: EX

| Pin | Description | |
|---------|----------------------|-------------|
| J | Valve Off | |
| 3 | Output (0 - 5 Vdc) | |
| 4 | +15 Vdc +24 Vdc | |
| 2 | Pwr Com NC | |
| F | -15 Vdc Pwr Com | |
| A | Setpoint (0 - 5 Vdc) | |
| B,C,10 | Signal Common | |
| 1 | Case Ground | |
| 5,6,8,9 | Not Connected | |
| I,D,E,H | Not Connected | |
| 7,G | Key Way | |
| J2 | J3 | |
| 3 | 3 | RS485 (DX-) |
| 4 | 4 | RS485 (DX+) |

Description: GX base I/O with 7003083 adapter

Model Code Option: FX/JX

| Pin | Description |
|-----|----------------------|
| 1 | Valve Control* |
| 2 | Output (0 - 5 Vdc) |
| 3 | +15 Vdc +24 Vdc |
| 4 | Pwr Com NC |
| 5 | -15 Vdc Pwr Com |
| 6 | Setpoint (0 - 5 Vdc) |
| 7 | Signal Common |
| 8 | Signal Common |
| 9 | Valve Test Point |

Description: SX base I/O with 7003069 (FX) / 7001814 (JX) adapter for compatibility with Unit UDF9 / UDJ9

Model Code Option: BX

| Pin | Description |
|----------|----------------------|
| 12 | Valve Override |
| 2 | Output (0 - 5 Vdc) |
| 5 | +15 Vdc +24 Vdc |
| 9 | Pwr Com NC |
| 6 | -15 Vdc Pwr Com |
| 8 | Setpoint (0 - 5 Vdc) |
| 1,10 | Signal Common |
| 3,4,7,11 | No Connection |
| 13,14,15 | No Connection |

Description: G1 base I/O with 7003590 adapter for compatibility with Brooks 15-Pin D

Model Code Option: KX

| Pin | Description |
|----------------|----------------------|
| 3 | Valve Control |
| 2 | Output (0 - 5 Vdc) |
| 7 | +15 Vdc +24 Vdc |
| 5 | Pwr Com NC |
| 6 | -15 Vdc Pwr Com |
| 8 | Setpoint (0 - 5 Vdc) |
| 11,12 | Signal Common |
| 15 | Case Ground |
| 1,4,9,10,13,14 | No Connection |

Description: G1 base I/O with 7003298 adapter for compatibility with Unit UDK15

Other adapter options are available for the GF Series.
Please contact Brooks Customer Service for more information.

Model Code - Standard Flow Range

| Code Description | Code Option | Option Description |
|-------------------------------------|-------------|--|
| I. Base Model Code | GF | High-Purity / Ultra-High Purity Digital Mass Flow Controllers |
| II. Package / Finish Specifications | 100 | Flow range 3 sccm - 55 slpm N ₂ Eq.; 1 sec Response; 10 Ra |
| | 120 | Flow range 3 sccm - 55 slpm N ₂ Eq.; 700 msec Response; 5 Ra |
| | 125 | Pressure Transient Insensitive (PTI) Flow range 3 sccm - 55 slpm N ₂ Eq.; ± 1.0% S.P. Accuracy; 300 - 700 msec Response; 5 Ra |
| III. Configurability | C | MultiFlo™ capable. Standard bins or specific gas / range may be selected. |
| | X | Not MultiFlo™ capable. Specific gas / range required (must select with SD, SL or HA special application). |
| IV. Special Application | XX | Standard |
| | SL | Safe Delivery System (GF120 Only) F.S. flow range; 4 - 25 sccm, N ₂ Eq. |
| | SD | Safe Delivery System (GF120 Only) F.S. flow range; > 25 sccm - 1 slpm, N ₂ Eq. |
| V. Valve Configuration | O | Normally Open Valve (not available with SD, SL or HA options) |
| | C | Normally Closed Valve (must select with SD, SL or HA special application) |
| | M | Meter (No Valve) |
| VI. Gas or SH MultiFlo™ Bin | XXXX XXXX | Specific Gas Code & Range, i.e. "0004" = Argon and "100L" = 100 slpm (must select with SD, SL or HA special application) |
| | SH40 010C | Standard Configuration #40, 3 - 10 sccm N ₂ Eq. (0°C Reference) |
| | SH41 030C | Standard Configuration #41, 11 - 30 sccm N ₂ Eq. (0°C Reference) |
| | SH42 092C | Standard Configuration #42, 31 - 92 sccm N ₂ Eq. (0°C Reference) |
| | SH43 280C | Standard Configuration #43, 93 - 280 sccm N ₂ Eq. (0°C Reference) |
| | SH44 860C | Standard Configuration #44, 281 - 860 sccm N ₂ Eq. (0°C Reference) |
| | SH45 2.6L | Standard Configuration #45, 861 - 2600 sccm N ₂ Eq. (0°C Reference) |
| | SH46 7.2L | Standard Configuration #46, 2601 - 7200 sccm N ₂ Eq. (0°C Reference) |
| | SH47 015L | Standard Configuration #47, 7201 - 15000 sccm N ₂ Eq. (0°C Reference) |
| | SH48 030L | Standard Configuration #48, 15001 - 30000 sccm N ₂ Eq. (0°C Reference) |
| | SH49 040L | Standard Configuration #49, 30001 - 40000 sccm N ₂ Eq. (0°C Reference) |
| | SH50 055L | Standard Configuration #50, 40001 - 55000 sccm N ₂ Eq. (0°C Reference) |
| VII. Fitting | VX | 1-1/2" body width, 124mm 1/4" VCR male |
| | VS | 1-1/8" body width, 124mm 1/4" VCR male |
| | CX | 1-1/8" body width, 92mm C Seal |
| | DX | 1-1/8" body width, 79.8mm C Seal |
| | EX | 1-1/2" body width, 79.8mm W Seal |
| | WX | 1-1/8" body width, 92mm W Seal |
| | YX | 1-1/8" body width, 79.8mm W Seal |
| | AX | 1-1/2" body width, 92mm C Seal |
| | BX | 1-1/2" body width, 92mm W Seal |
| | LX | 1-1/8" body width, 92mm C Seal with Poke Yoke |
| | AS | 1-1/2" body width, 92mm 0.440" large bore C Seal (only for bins SH45-SH50) |
| VIII. Downstream | A | Atmosphere |
| | V | Vacuum; Default for SD, SL and HA special application |
| IX. Sensor | O | Default Sensor Orientation |

Code Description

Code Option Option Description

| | | |
|-------------------------------|----|---|
| X. Communications / Connector | BX | Cable adapter to 15-pin D Brooks; adapts G1 base |
| | EX | Cable adapter to card edge (without VTP), RS485 through RJ11 jacks; adapts GX base (Not Available on 79.8mm fitting DX, YX, EX) |
| | FX | Cable adapter with 9-pin STEC pin-out & jack screws (with VTP); adapts SX base |
| | GX | 9-Pin D with RS485 (Not Available on 79.8mm fitting DX, YX, EX) |
| | G1 | 9-Pin D with RS485 |
| | JX | Cable adapter with 9-pin STEC pin-out & jack screws (with VTP); adapts SX base |
| | KX | Cable adapter to MKS 15-Pin D; adapts G1 base |
| | SX | 9-pin D with STEC pin-out (with VTP) |
| | TX | 9-pin D with UDT9 pin-out (UDT9) (Not Available on 79.8mm fitting DX, YX, EX) |
| | UX | Cable adapter to 15-pin D (with VTP); adapts SX base |
| | BB | DeviceNet™ Analog (Not Available on 79.8mm fitting DX, YX, EX) |

DeviceNet Standard Configuration Parameters

| Code Option | I/O | Connector | Power On State | Full Scale Setting | Full Scale Setting | Full Scale Setting | Poll I/O Instance Producer | Poll I/O Instance Consumer | Poll I/O State Transition | External Baud Rate |
|-------------|-----------|-------------|---|--------------------|--------------------|--------------------|----------------------------|----------------------------|---------------------------|--------------------|
| D0 | DeviceNet | 5-Pin Micro | Idle | Count | Integer | 6000h | 2 | 7 | Executing | 500KB |
| D1 | DeviceNet | 5-Pin Micro | Idle | Count | Integer | 6000h | 21 | 7 | Executing | 500KB |
| D2 | DeviceNet | 5-Pin Micro | Idle | SCCM | Float | 7FFFh | 13 | 19 | Executing | 500KB |
| D3 | DeviceNet | 5-Pin Micro | Idle | Count | Integer | 6000h | 22 | 7 | Executing | 500KB |
| D4 | DeviceNet | 5-Pin Micro | Executing | Count | Integer | 6000h | 22 | 8 | Executing | 500KB |
| D5 | DeviceNet | 5-Pin Micro | Idle | Count | Integer | 6000h | 6 | 8 | Executing | 500KB |
| D6 | DeviceNet | 5-Pin Micro | Idle | Count | Integer | 7FFFh | 3 | 7 | Executing | 500KB |
| D7 | DeviceNet | 5-Pin Micro | Idle | Count | Integer | 7FFFh | 6 | 8 | Executing | 500KB |
| D8 | DeviceNet | 5-Pin Micro | Idle | Count | Integer | 6000h | 3 | 7 | Executing | 500KB |
| D9 | DeviceNet | 5-Pin Micro | Executing | Count | Integer | 6000h | 2 | 7 | Executing | 500KB |
| DA | DeviceNet | 5-Pin Micro | Idle | Count | Integer | 7FFFh | 22 | 7 | Executing | 500KB |
| DB | DeviceNet | 5-Pin Micro | Idle | Count | Integer | 6000h | 22 | 8 | Executing | 500KB |
| DC | DeviceNet | 5-Pin Micro | Idle | Count | Integer | 7FFFh | 3 | 7 | Idle | 500KB |
| DD | DeviceNet | 5-Pin Micro | Executing | Count | Integer | 7FFFh | 22 | 8 | Executing | 500KB |
| DE | DeviceNet | 5-Pin Micro | Executing | SCCM | Float | 6000h | 15 | 19 | Executing | 500KB |
| DX | DeviceNet | 5-Pin Micro | To be defined by Customer Special Request | | | | | | | |

| | | |
|------------------------------|------|--|
| XI. Customer Special Request | XXXX | Customer Special Request Number; required with "DX, BB" Conn. Option to define DNet settings |
|------------------------------|------|--|

| | | |
|--------------------|---|--|
| XII. Auto Shut-Off | A | Auto Shut-Off (Included) Default for SD and SL special application |
| | X | Auto Shut-Off (Not Included) (Must be selected for meter) |

| | | |
|-----------------|---|--------------------------|
| XIII. Auto Zero | X | Auto Zero (Not Included) |
|-----------------|---|--------------------------|

| | | |
|----------------------------|-----|--|
| XIV. Reference Temperature | 000 | 0°C Reference Calibration (Standard) - Default Setting |
|----------------------------|-----|--|

Sample Standard Model Code

| | | | | | | | | | | | | | | | | | |
|----|-----|-----|----|---|---|-----------|---|-----|------|----|----|---|------|-----|------|---|-----|
| I | II | III | IV | V | - | VI | - | VII | VIII | IX | X | - | XI | XII | XIII | - | XIV |
| GF | 100 | C | XX | M | - | SH40 010C | - | VX | A | O | GX | - | XXXX | A | X | - | 000 |

Sample Safe Delivery System (SDS) Model Code

| | | | | | | | | | | | | | | | | | |
|----|-----|-----|----|---|---|-----------|---|-----|------|----|----|---|------|-----|------|---|-----|
| I | II | III | IV | V | - | VI | - | VII | VIII | IX | X | - | XI | XII | XIII | - | XIV |
| GF | 120 | X | SD | C | - | XXXX XXXX | - | EX | V | O | SX | - | XXXX | A | X | - | 000 |

Model Code - High Flow Range

| Code Description | Code Option | Option Description |
|-------------------------------------|-----------------------|---|
| I. Base Model Code | GF | High-Purity / Ultra-High Purity Digital Mass Flow Controllers |
| II. Package / Finish Specifications | 101 | Flow range 55 - 300 sIm N ₂ Eq.; 10 Ra HP wetted flow path |
| | 121 | Flow range 55 - 300 sIm N ₂ Eq.; 5 Ra UHP wetted flow path |
| | 126 | Flow range 55 - 300 sIm N ₂ Eq.; 5 Ra UHP wetted flow path & integrated pressure measurement |
| III. Configurability | C | MultiFlo™ capable |
| | X | Not configurable |
| IV. Special Application | XX | Standard |
| V. Valve Configuration | C | Normally Closed Valve |
| | M | Meter (No Valve) |
| VI. Gas or SH MultiFlo™ Bin | XXXX XXXX | Specific Gas Code & Range, i.e. "0004" = Argon and "100L" = 100 slpm |
| | SH51 055L | Standard Configuration #51, 55,001 sccm N ₂ Equivalent (0 °C Reference) Special Bin for low density gases, e.g. 73,002 - 120,000 He, 100,002 - 170,000 H ₂ |
| | SH52 100L | Standard Configuration #52, 55,002 - 100,000 sccm N ₂ Equivalent (0°C Reference) |
| | SH53 200L | Standard Configuration #53, 100,001 - 200,000 sccm N ₂ Equivalent (0°C Reference) |
| | SH54 300L | Standard Configuration #54, 200,001 - 300,000 sccm N ₂ Equivalent (0°C Reference) |
| VII. Fitting | V1 | 1 - 1/2" body width, 134mm 1/2" VCR male |
| | V2 | 1 - 1/2" body width, 150.4mm 1/2" VCR male |
| | V3 | 1 - 1/2" body width, 166mm 1/2" VCR male |
| | V4 | 1 - 1/2" body width, 168.6mm 1/2" VCR male |
| | Order V1 + 318Z138BNA | 1 - 1/2" body width, 192.4mm 1/2" VCR male |
| | C1 | 1 - 1/2" body width, 92mm 3/8" C Seal |
| | C2 | 1 - 1/2" body width, 114mm 3/8" C Seal |
| VIII. Downstream | A | Atmosphere |
| | V | Vacuum |
| IX. Sensor | O | Default Sensor Orientation |

Code Description

Code Option Option Description

| | | | | | | | | | | | |
|-------------------------------|--|--|---|-----------------------|---------------------------|---------------------------|---------------------------|-----------------------------------|-----------------------------------|----------------------------------|---------------------------|
| X. Communications / Connector | BX | Cable adapter to 15-pin D Brooks; adapts G1 base | | | | | | | | | |
| | EX | Cable adapter to card edge (without VTP), RS485 through RJ11 jacks; adapts G1 base | | | | | | | | | |
| | FX | Cable adapter with 9-pin STEC pin-out & jack screws (with VTP); adapts SX base | | | | | | | | | |
| | G1 | 9-Pin D with RS485 | | | | | | | | | |
| | GX | 9-Pin D with RS485 (Not Available on 79.8mm fitting DX, YX, EX) | | | | | | | | | |
| | JX | Cable adapter with 9-pin STEC pin-out & jack screws (with VTP); adapts SX base | | | | | | | | | |
| | KX | Cable adapter to MKS 15-Pin D; adapts G1 base | | | | | | | | | |
| | SX | 9-pin D with STEC pin-out (with VTP) | | | | | | | | | |
| | UX | Cable adapter to 15-pin D (with VTP); adapts SX base | | | | | | | | | |
| | DeviceNet Standard Configuration Parameters | | | | | | | | | | |
| | Code Option | I/O | Connector | Power On State | Full Scale Setting | Full Scale Setting | Full Scale Setting | Poll I/O Instance Producer | Poll I/O Instance Consumer | Poll I/O State Transition | External Baud Rate |
| | D0 | DeviceNet | 5-Pin Micro | Idle | Count | Integer | 6000h | 2 | 7 | Executing | 500KB |
| | D1 | DeviceNet | 5-Pin Micro | Idle | Count | Integer | 6000h | 21 | 7 | Executing | 500KB |
| | D2 | DeviceNet | 5-Pin Micro | Idle | SCCM | Float | 7FFFh | 13 | 19 | Executing | 500KB |
| | D3 | DeviceNet | 5-Pin Micro | Idle | Count | Integer | 6000h | 22 | 7 | Executing | 500KB |
| | D4 | DeviceNet | 5-Pin Micro | Executing | Count | Integer | 6000h | 22 | 8 | Executing | 500KB |
| | D5 | DeviceNet | 5-Pin Micro | Idle | Count | Integer | 6000h | 6 | 8 | Executing | 500KB |
| | D6 | DeviceNet | 5-Pin Micro | Idle | Count | Integer | 7FFFh | 3 | 7 | Executing | 500KB |
| | D7 | DeviceNet | 5-Pin Micro | Idle | Count | Integer | 7FFFh | 6 | 8 | Executing | 500KB |
| D8 | DeviceNet | 5-Pin Micro | Idle | Count | Integer | 6000h | 3 | 7 | Executing | 500KB | |
| D9 | DeviceNet | 5-Pin Micro | Executing | Count | Integer | 6000h | 2 | 7 | Executing | 500KB | |
| DA | DeviceNet | 5-Pin Micro | Idle | Count | Integer | 7FFFh | 22 | 7 | Executing | 500KB | |
| DB | DeviceNet | 5-Pin Micro | Idle | Count | Integer | 6000h | 22 | 8 | Executing | 500KB | |
| DC | DeviceNet | 5-Pin Micro | Idle | Count | Integer | 7FFFh | 3 | 7 | Idle | 500KB | |
| DD | DeviceNet | 5-Pin Micro | Executing | Count | Integer | 7FFFh | 22 | 8 | Executing | 500KB | |
| DE | DeviceNet | 5-Pin Micro | Executing | SCCM | Float | 6000h | 15 | 19 | Executing | 500KB | |
| DX | DeviceNet | 5-Pin Micro | To be defined by Customer Special Request | | | | | | | | |
| XI. Customer Special Request | XXXX | Customer Special Request Number | | | | | | | | | |
| XII. Auto Shut-Off | A | Auto Shut-Off (Included) | | | | | | | | | |
| | X | Auto Shut-Off (Not Included) (Must be selected for meter) | | | | | | | | | |
| XIII. Auto Zero | A | Auto Zero (Included) | | | | | | | | | |
| | X | Auto Zero (Not Included) | | | | | | | | | |
| XIV. Reference Temperature | 000 | 0°C Reference Calibration (Standard) - Default Setting | | | | | | | | | |

Sample High Flow Range Model Code

| | | | | | | | | | | | | | | | | | |
|----|-----|-----|----|---|---|-----------|---|-----|------|----|----|---|------|-----|------|---|-----|
| I | II | III | IV | V | | VI | | VII | VIII | IX | X | | XI | XII | XIII | | XIV |
| GF | 101 | C | XX | C | - | SH52 100L | - | V1 | A | O | G1 | - | XXXX | A | X | - | 000 |

Brooks is committed to assuring all of our customers receive the ideal flow solution for their application, along with outstanding service and support to back it up. We operate first class repair facilities located around the world to provide rapid response and support. Each location utilizes primary standard calibration equipment to ensure accuracy and reliability for repairs and recalibration and is certified by our local Weights and Measures Authorities and traceable to the relevant International Standards.

Visit www.BrooksInstrument.com to locate the service location nearest to you.

START-UP SERVICE AND IN-SITU CALIBRATION

Brooks Instrument can provide start-up service prior to operation when required. For some process applications, where ISO-9001 Quality Certification is important, it is mandatory to verify and/or (re)calibrate the products periodically. In many cases this service can be provided under in-situ conditions, and the results will be traceable to the relevant international quality standards.

SEMINARS AND TRAINING

Brooks Instrument can provide customer seminars and dedicated training to engineers, end users, and maintenance persons. *Please contact your nearest sales representative for more details.* Due to Brooks Instrument's commitment to continuous improvement of our products, all specifications are subject to change without notice.



TRADEMARKS

Brooks.....Brooks Instrument, LLC
All other trademarks are the property of their respective owners.

Data-Sheet-GF100-EN/2025-01

The logo for Contech, featuring the word 'Contech' in a bold, white, sans-serif font with a horizontal line under the 't'.

Av. Dr. Lino de Moraes Leme, 1.094
Vila Paulista – São Paulo/SP – 04360-000.
+55 11 5035-0920
Atendimento@contechind.com.br

www.contechind.com.br