

Alerta de Fluxo Bi Direcional



SPECIFICATIONS:

· MATERIALS:

- 2024 – T351 Anodized aluminum body, piston and cone
- C360 Brass body, piston and cone
- T303 Stainless body, 2024 – T351 Anodized aluminum piston and cone (Oil, PE, WBF, & Air meters)
- T303 Stainless body, C360 Brass piston and cone (Water meters)
- T316 Stainless body, piston and cone

· PETROLEUM (Oil) COMMON PARTS:

- Spider Plate: T316 SS Retaining Ring: SAE 1070/1090 Carbon Steel
- Spring: T302 SS Retaining Spring: SAE 1070/1090 Carbon Steel
- Fasteners: T303 SS Internal Magnet: Teflon® Coated Alnico 8
- Pressure Seals: Viton® Enclosure Seal: Silicone gasket
- Lens: Polycarbonate

· PHOSPHATE ESTER (PE) COMMON PARTS:

- Spider Plate: T316 SS Retaining Ring: SAE 1070/1090 Carbon Steel
- Spring: T302 SS Retaining Spring: SAE 1070/1090 Carbon Steel
- Fasteners: T303 SS Internal Magnet: Teflon® Coated Alnico 8
- Pressure Seals: EPR Enclosure Seal: Silicone gasket
- Lens: Polycarbonate

- WATER-BASED (WBF), WATER, AIR COMMON PARTS: Spider Plate: T316 SS Retaining Ring: T316 SS
- Spring: T302 SS Retaining Spring: T316 SS
- Fasteners: T303 SS Internal Magnet: Teflon® Coated Alnico 8
- Pressure Seals: Viton® Enclosure Seal: Silicone gasket
- Lens: Polycarbonate

· API OIL / AIR / CAUSTIC and CORROSIVE LIQUIDS and GASES:

- Spider Plate: T316 SS Retaining Ring: T316 SS
- Spring: T316 SS Retaining Spring: T316 SS
- Fasteners: T316 SS Internal Magnet: Teflon® Coated Alnico 8
- Pressure Seals: Viton® Enclosure Seal: Silicone gasket
- Lens: Polycarbonate

· THREADS: SAE J1926/1, NPTF ANSI B2.2, BSPP ISO1179

· TEMPERATURE RANGE: -20 to +240 °F (-29 to +116 °C)

· PRESSURE RATING:

Aluminum / Brass Operating:

- Liquids – 3,500 psi/241 bar maximum with a 3:1 safety factor.
- Gases – 1,000 psi/69 bar maximum with a 10:1 safety factor.
- For High Cycle Applications: See page 7

Stainless Steel Operating:

- Liquids – (1/4" to 1/2") – 6,000 psi/414 bar maximum with a 3:1 safety factor
- Liquids – (3/4" to 1-1/2") – 5,000 psi/345 bar maximum with a 3:1 safety factor
- Gases – 1,500 psi/103 bar maximum with a 10:1 safety factor.
- For High Cycle Applications: See page 7

ACCURACY: ±2% of full scale					REPEATABILITY: ±1%			
PRESSURE DROP REFERENCE TABLE:								
FLUID TYPE								
	Oil	PE	WBF	Water	API Oil	Caustic & Corrosive Liquids	Air/Caustic & Corrosive Gases	Air
50% / 100% Pressure Drop	p. 10	p. 16	p. 22	p. 28	p. 32	p. 32	p. 34	p. 36
Pressure Drop Chart	p. 55	p. 56	p. 57	p. 58	p. 59	p. 58	p. 59	p. 60

GOOD VISCOSITY STABILITY

ENCLOSURE:

- Material: Anodized and epoxy powder-coated aluminum with polycarbonate lens
- Seals: Silicone gaskets between enclosure and lens Viton® O-rings between enclosure and flow meter body
- Connection: 4-pin (Protection Class IP65) standard, see Figure 2 Other connections available – consult factory for details
- Fasteners: T303 SS
- Rating: NEMA 12 & 13 (IP 52/54)

ELECTRICAL SPECIFICATIONS:

Power

- Requirement: 0–5 VDC Output: 10–30 VDC @ 0.75W maximum
- 0–10 VDC Output: 12–30 VDC @ 0.75W maximum
- 4–20 mA Output: loop-powered, 30 VDC maximum

Power

- Consumption: 25 mA maximum

Analog

- Outputs: 0–5 VDC and 0–10 VDC into 10,000 Ohms minimum
- 4–20 mA into 1000 Ohms maximum, see Figure 1

Circuit

- Protection: Reverse polarity and current limiting

Transmission

- Distance: 4–20 mA limited by cable resistance 0–5 VDC and 0–10 VDC 1000 feet (300 m) maximum
- Isolation: Inherently isolated from the piping system
- Display: Fixed or toggle modes of operation for rate and totalizer display 8 digit, 0.70" high numeric display for rate and total 8 digit, 0.35" high alphanumeric display for units and setup

Temperature

- Drift: 50 ppm / °C (max)
- Analog Output: Resolution – 1:4000

Transient

- Over-Voltages: Category 3, in accordance with IEC 664

Pollution

- Degree: Category 2, in accordance with IEC 664
- Approvals: CE compliant

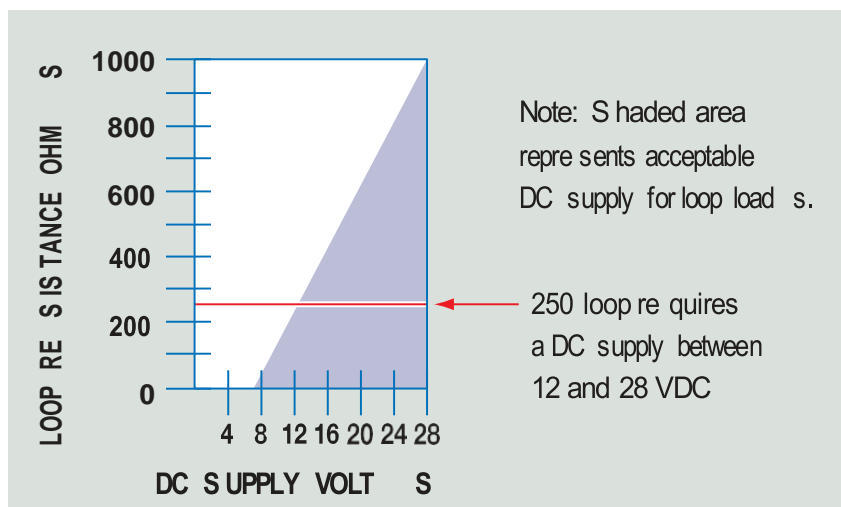
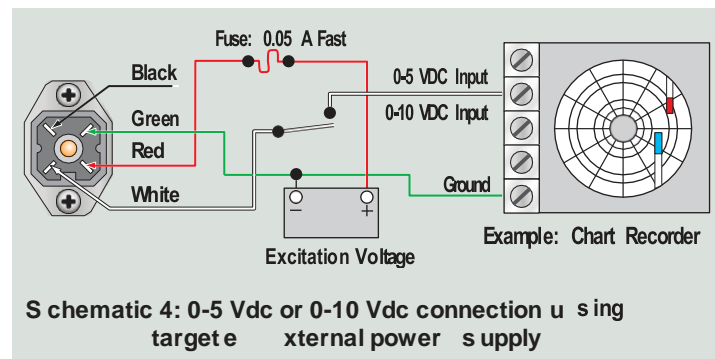
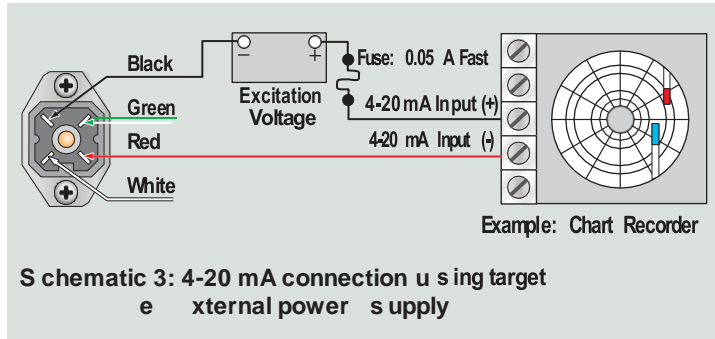
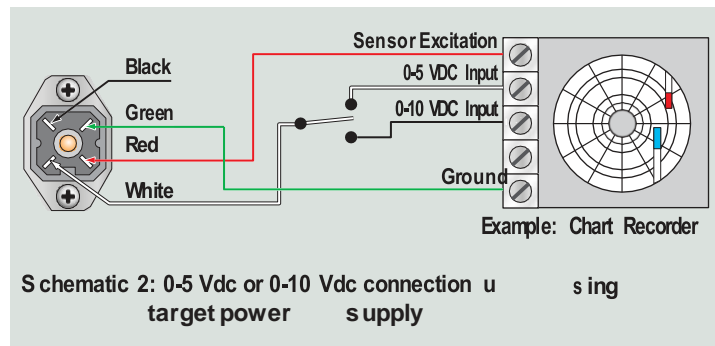
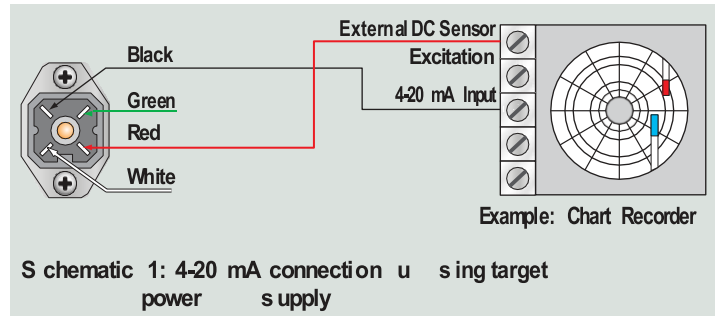

Figure 1. Load Limitations (4-20 mA Output Only)

SCHEMATICS:

The transmitter can be wired in various configurations to allow interface with many different types of data collection and control instrumentation. Schematics 1 & 2 represent typical wiring for a target powered by either AC power or DC supply. Schematics 3 & 4 will be utilized when the flow transmitter is operated with loop-powered process indicators or data loggers that do not have external sensor excitation available.



	DC Output Connection	Loop Power Connection
2 Black:	No Connection	(-) 4-20 mA Out
3 Green:	0 VDC	No Connection
1 Red:	(+) DC Power	(+) 4-20 mA In
4 White:	0-5 VDC or 0-10 VDC Output	No Connection

Dimensions:

A	B	C	D	E	F	G	H	I	J	K
Nomial PortSize	Length In. (mm)	Length In. (mm)	Length In. (mm)	Width In. (mm)	Width In. (mm)	Width In. (mm)	Width In. (mm)	Depth In. (mm)	Offset In. (mm)	Hub Dia In. (mm)
1/4 (SAE 6)	6.60 (168)	5.27 (134)	6.41 (163)	6.00 (152)	3.23 (82)	3.00 (67)	4.20 (107)	2.4 (75)	1.51 (38)	.31 (8)
1/2 (SAE 10)	6.60 (168)	5.27 (134)	6.41 (163)	6.00 (152)	3.23 (82)	3.00 (67)	4.20 (107)	2.4 (75)	1.51 (38)	.31 (8)
3/4 (SAE 12)	7.20 (183)	5.27 (134)	7.04 (197)	6.00 (152)	3.60 (91)	3.00 (76)	4.20 (107)	2.4 (75)	1.27 (32)	.31 (8)
1 (SAE 16)	7.20 (183)	5.27 (134)	7.04 (197)	6.00 (152)	3.60 (91)	3.00 (76)	4.20 (107)	2.4 (75)	1.27 (32)	.31 (8)
1-1/4 (SAE 20)	12.20 (310)	106.8 (271)	116.5 (296)	7.63 (194)	4.84 (123)	3.82 (97)	5.02 (128)	4.50 (114)	2.20 (65)	.31 (8)
1-1/2 (SAE 24)	12.20 (310)	106.8 (271)	116.5 (296)	7.63 (194)	4.84 (123)	3.82 (97)	5.02 (128)	4.50 (114)	2.20 (65)	.31 (8)



Optional Remote Display and Signal Processor:

Hedland also offers the F6700/F6750 Series Digital Display with integrated signal processor capabilities to further enhance the utility of the MR Flow Transmitters. In addition to remote flow monitoring, these units can be configured to provide alarm processing and communication options including RS232, RS485, Modbus, Profibus and DeviceNet. For complete product specifications, refer to page 53.



ORDERING INFORMATION:

NOMINAL PORT SIZE ^①	FLOW RANGE		MODEL NUMBER (see example below)			MATERIAL			OPTIONS		
	GPM	LPM	SAE	NPTF	BSPP	ALUMINUM 3500 PSI	BRASS 3500 PSI	STAINLESS	Flow-Alert 1 SWITCH / 2 SWITCH	Flow-Alert REED SWITCH	MULTIPLE OUTPUT SENSOR
1/4" SAE 6	.02 - 0.2	0.1 - 0.75	H200* - 002 - †	H201* - 002 - †	H202* - 002 - †	A	B	6000 PSI	NotAvailable	SEE	NotAvailable
	.05 - 0.5	0.2 - 1.9	H200* - 005 - †	H201* - 005 - †	H202* - 005 - †	A	B	6000 PSI	F1/F2		
1/4" SAE 6	0.1 - 1.0	0.5 - 3.75	H200* - 010 - †	H201* - 010 - †	H202* - 010 - †	A	B	6000 PSI	F1/F2	OPT	MR
	0.2 - 2.0	1 - 7.5	H200* - 020 - †	H201* - 020 - †	H202* - 020 - †	A	B	6000 PSI	F1/F2		
1/2" SAE 10	0.1 - 1.0	0.5 - 3.75	H600* - 001 - †	H601* - 001 - †	H602* - 001 - †	A	B	6000 PSI	F1/F2	IONS	MR
	0.2 - 2.0	1 - 7.5	H600* - 002 - †	H601* - 002 - †	H602* - 002 - †						
	0.5 - 5.0	2 - 19	H600* - 005 - †	H601* - 005 - †	H602* - 005 - †						
	1 - 10	5 - 38	H600* - 010 - †	H601* - 010 - †	H602* - 010 - †						
	1 - 15	4 - 56	H600* - 015 - †	H601* - 015 - †	H602* - 015 - †						
3/4" SAE 12	0.2 - 2.0	1 - 7.5	H700* - 002 - †	H701* - 002 - †	H702* - 002 - †	A	B	5000 PSI	F1/F2	LOW	MR
	0.5 - 5.0	2 - 19	H700* - 005 - †	H701* - 005 - †	H702* - 005 - †						
	1 - 10	5 - 38	H700* - 010 - †	H701* - 010 - †	H702* - 010 - †						
	2 - 20	10 - 76	H700* - 020 - †	H701* - 020 - †	H702* - 020 - †						
	3 - 30	10 - 115	H700* - 030 - †	H701* - 030 - †	H702* - 030 - †						
1" SAE 16	0.2 - 2.0	1 - 7.5	H760* - 002 - †	H761* - 002 - †	H762* - 002 - †	A	B	5000 PSI	F1/F2	MR	MR
	0.5 - 5.0	2 - 19	H760* - 005 - †	H761* - 005 - †	H762* - 005 - †						
	1 - 10	5 - 38	H760* - 010 - †	H761* - 010 - †	H762* - 010 - †						
	2 - 20	10 - 76	H760* - 020 - †	H761* - 020 - †	H762* - 020 - †						
	3 - 30	10 - 115	H760* - 030 - †	H761* - 030 - †	H762* - 030 - †						
	4 - 40	10 - 150	H760* - 040 - †	H761* - 040 - †	H762* - 040 - †						
1-1/4" SAE 20	3 - 30	10 - 110	H800* - 030 - †	H801* - 030 - †	H802* - 030 - †	A	B	5000 PSI	F1/F2	MR	MR
	5 - 50	20 - 190	H800* - 050 - †	H801* - 050 - †	H802* - 050 - †						
	10 - 75	40 - 280	H800* - 075 - †	H801* - 075 - †	H802* - 075 - †						
	10 - 100	50 - 380	H800* - 100 - †	H801* - 100 - †	H802* - 100 - †						
	10 - 150	50 - 560	H800* - 150 - †	H801* - 150 - †	H802* - 150 - †						
1-1/2" SAE 24	3 - 30	10 - 110	H860* - 030 - †	H861* - 030 - †	H862* - 030 - †	A	B	5000 PSI	F1/F2	MR	MR
	5 - 50	20 - 190	H860* - 050 - †	H861* - 050 - †	H862* - 050 - †						
	10 - 75	40 - 280	H860* - 075 - †	H861* - 075 - †	H862* - 075 - †						
	10 - 100	50 - 380	H860* - 100 - †	H861* - 100 - †	H862* - 100 - †						
	10 - 150	50 - 560	H860* - 150 - †	H861* - 150 - †	H862* - 150 - †						

①Fractional sizes apply to NPTF and BSPP.

(example) H701 A - 030 - F1 or F2



Flow-Alert Flow Switches

F1 = Single Switch
F2 = Double Switch

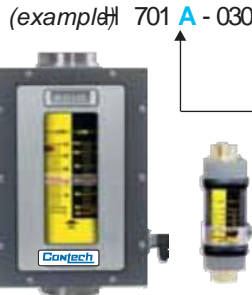

(example) H701 A - 030 - RS1NO

Flow-Alert Reed Switches

Options:

- RS1NO (reed switch one (1) normally open)
- RS2NO (reed switch two (2) normally open)
- RS1NC (reed switch one (1) normally closed)
- RS2NC (reed switch two (2) normally closed)

(example) H701 A - 030 - MR



Multiple Output Flow Sensor

3 Standard field selectable outputs

0-5 VDC } Flow Transmitter is factory-calibrated to provide 4 mA (0 VDC) at zero flow
0-10 VDC } and 20 mA (5/10 VDC) at full flow. Optional 5-point calibration certificate available
4-20 mA } (see Price and Availability Digest for details).

NOTE: 1/4" liquid meters for .02-0.2 and .05-0.5 GPM ranges available in strap-on design for RS1NO and RS1NC only.

NOTE: For 50% and 100% flow/pressure drop information, see page 10. For detailed flow/pressure drop charts, see page 55.

Contech

Av. Dr. Lino de Moraes Leme, 1.094
Vila Paulista – São Paulo/SP – 04360-000.
+55 11 5035-0920
Atendimento@contechind.com.br

www.contechind.com.br