

## Installation and Operation Manual

X-VA-MT 3750C-eng  
Part Number: 541B063  
October, 2008

# Ar-Mite™ Low Flow Armored Flowmeter



*Ar-Mite™ Model MT 3750  
Metal Tube Flowmeter*



*Ar-Mite™ Model MT 3750  
Metal Tube Flowmeter  
with Transmitter or Inductive Alarm*

# Essential Instructions

## Read this page before proceeding!

Brooks Instrument designs, manufactures and tests its products to meet many national and international standards. Because these instruments are sophisticated technical products, you must properly install, use and maintain them to ensure they continue to operate within their normal specifications. The following instructions must be adhered to and integrated into your safety program when installing, using and maintaining Brooks Products.

- Read all instructions prior to installing, operating and servicing the product. If this instruction manual is not the correct manual, please see back cover for local sales office contact information. Save this instruction manual for future reference.
- If you do not understand any of the instructions, contact your Brooks Instrument representative for clarification.
- Follow all warnings, cautions and instructions marked on and supplied with the product.
- Inform and educate your personnel in the proper installation, operation and maintenance of the product.
- Install your equipment as specified in the installation instructions of the appropriate instruction manual and per applicable local and national codes. Connect all products to the proper electrical and pressure sources.
- To ensure proper performance, use qualified personnel to install, operate, update, program and maintain the product.
- When replacement parts are required, ensure that qualified people use replacement parts specified by Brooks Instrument. Unauthorized parts and procedures can affect the product's performance and place the safe operation of your process at risk. Look-alike substitutions may result in fire, electrical hazards or improper operation.
- Ensure that all equipment doors are closed and protective covers are in place, except when maintenance is being performed by qualified persons, to prevent electrical shock and personal injury.

## Pressure Equipment Directive (PED)

All pressure equipment with an internal pressure greater than 0.5 bar (g) and a size larger than 25mm or 1" (inch) falls under the Pressure Equipment Directive (PED). The Directive is applicable within the European Economic Area (EU plus Norway, Iceland and Liechtenstein). Pressure equipment can be traded freely within this area once the PED has been complied with.

- Section 1 of this manual contains important safety and operating instructions related to the PED directive.
- Meters described in this manual are in compliance with EN directive 97/23/EC module H *Conformity Assessment*.
- All Brooks Instrument Flowmeters fall under fluid group 1.
- Meters larger than 25mm or 1" (inch) are in compliance with category I, II, III of PED.
- Meters of 25mm or 1" (inch) or smaller are Sound Engineering Practice (SEP).

## ESD (Electrostatic Discharge)

### CAUTION

**This instrument contains electronic components that are susceptible to damage by static electricity. Proper handling procedures must be observed during the removal, installation or other handling of circuit boards or devices.**

#### Handling Procedure:

1. Power to unit must be removed.
2. Personnel must be grounded, via a wrist strap or other safe, suitable means before any printed circuit card or other internal device is installed, removed or adjusted.
3. Printed circuit cards must be transported in a conductive container. Boards must not be removed from protective enclosure until immediately before installation. Removed boards must immediately be placed in protective container for transport, storage or return to factory.

#### Comments

*This instrument is not unique in its content of ESD (electrostatic discharge) sensitive components. Most modern electronic designs contain components that utilize metal oxide technology (NMOS, SMOS, etc.). Experience has proven that even small amounts of static electricity can damage or destroy these devices. Damaged components, even though they appear to function properly, exhibit early failure.*

## **Installation and Operation Manual**

X-VA-MT 3750C-eng  
Part Number: 541B063  
October, 2008

Dear Customer,

We appreciate this opportunity to service your flow measurement and control requirements with a Brooks Instrument device. Every day, flow customers all over the world turn to Brooks Instrument for solutions to their gas and liquid low-flow applications. Brooks provides an array of flow measurement and control products for various industries from biopharmaceuticals, oil and gas, fuel cell research and chemicals, to medical devices, analytical instrumentation, semiconductor manufacturing, and more.

The Brooks product you have just received is of the highest quality available, offering superior performance, reliability and value to the user. It is designed with the ever changing process conditions, accuracy requirements and hostile process environments in mind to provide you with a lifetime of dependable service.

We recommend that you read this manual in its entirety. Should you require any additional information concerning Brooks products and services, please contact your local Brooks Sales and Service Office listed on the back cover of this manual or visit [www.BrooksInstrument.com](http://www.BrooksInstrument.com)

Yours sincerely,  
Brooks Instrument

*THIS PAGE WAS  
INTENTIONALLY  
LEFT BLANK*

<b><u>Paragraph Number</u></b>	<b><u>Page Number</u></b>
<b>Introduction Section 1</b>	
1-1 Description .....	1-1
1-2 Specifications .....	1-1
1-3 Optional Equipment .....	1-4
<b>Installation Section 2</b>	
2-1 General .....	2-1
2-2 Receipt of Equipment .....	2-1
2-3 Recommended Storage Practice .....	2-1
2-4 Return Shipment .....	2-2
2-5 Transit Precautions .....	2-2
2-6 Removal From Storage .....	2-2
2-7 Installation of Flowmeter .....	2-3
2-8 Installation of Inductive Alarm .....	2-3
2-9 Installation of Reed Switch Alarm .....	2-4
2-10 Installation of Transmitter .....	2-5
<b>Operation Section 3</b>	
3-1 Operating Procedure .....	3-1
3-2 Operation of Inductive Alarm .....	3-1
3-3 Operation of Transmitter .....	3-1
3-4 Operation of Reed Switch Alarm .....	3-2
<b>Maintenance Section 4</b>	
4-1 General .....	4-1
4-2 Service Information .....	4-1
4-3 On Site Adjustment/Calibration .....	4-1
<b>Parts List Section 5</b>	
5-1 General .....	5-1
<b>Warranty, Local Sales/Service Contact Information .....</b>	<b>Back Cover</b>

Brooks® Ar-Mite™ MT 3750C

Figures

<u>Figure Number</u>	<u>Page Number</u>
1-1 Model MT 3750C with Reed Switch Alarm .....	1-5
1-2 Reed Switch Wiring Diagram .....	1-6
1-3 Model MT 3750C with Transmitter / Inductive Alarm .....	1-7
1-4 Power Supply vs. Maximum Load Resistance .....	1-10
1-5 Transmitter Wiring Diagram .....	1-10
1-6 Dimensions for MT 3750C Flanged and Threaded Metal Tube Flowmeter with Indicator .....	1-11
1-7 Dimensions for MT 3750C Flanged and Threaded Connections with Transmitter or Inductive Alarm .....	1-12
1-8 Dimensions for MT 3750C Flanged and Threaded Connections with Reed Switch Alarm .....	1-13
1-9 Dimensions for MT 3750C Panel Mounting .....	1-14
2-1 Typical Installation .....	2-3
2-2 Inductive Switch Wiring Diagram .....	2-4
2-3 Inductive Switch Wiring .....	2-6
2-4 Reed Switch Alarm Wiring Using IS Barrier .....	2-7
2-5 Reed Switch Alarm Installation using P & F Relay Unit .....	2-8
2-6 Reed Switch Alarm Wiring Using P & F Relay Unit .....	2-8
2-7 Transmitter Wiring Diagram for I.S. Systems .....	2-9
2-8 Transmitter Wiring Diagram for XP Systems .....	2-10
2-9 Transmitter Wiring Diagram .....	2-11
3-1 Reed Switch Alarm .....	3-4
5-1 Model MT 3750 Exploded View .....	5-2

Tables

<u>Table Number</u>	<u>Page Number</u>
1-1 Capacities .....	1-3
1-2 Pressure Ratings in PSIG (Bar G) .....	1-3
1-3 Fluid Temperature at Ambient Temperature .....	1-3
3-1 Interior Label MT 3750 Ar-Mite Alarm .....	3-3
5-1 Model MT 3750 Recommended Spare Parts List (Refer to Figure 5-1) .....	5-3
5-2 Model MT 3750 Indicator, Alarm and Transmitter Spare Parts List .....	5-4

## 1-1 Description

The Brooks® Ar-Mite™ is a reliable, low flow metal tube flowmeter with 316L stainless steel wetted parts. The magnetically coupled indicator provides a highly reliable method of indication. This model is a practical and economical approach to low flow rate indication for high pressure and difficult to handle fluids. Optional accessories include 4-20 mA output, Needle Valve, Flow Controllers and Alarms.

## 1-2 Specifications

### **WARNING**

**Do not operate this instrument in excess of the specifications listed below. Failure to heed this warning can result in serious personal injury and/or damage to the equipment.**

#### **Performance Specifications**

##### **Flow**

Liquids up to 100 l/h or 26 GPH (Water equiv.)  
Gases up to 3.1 m<sup>3</sup>/h or 120 SCFH (Air equiv.)  
(See Table 1-1 for more information)

##### **Accuracy**

±5% Full Scale, Class 4 to VDE/VDI 3513,  
Optional ±3% Full Scale, Class 2.5 to VDE/VDI 3513

##### **Repeatability**

1% full scale

##### **Pressure Ratings**

###### **Maximum fluid pressure:**

All non-flanged meters: 1500 psig (100 bar)  
Flange connections: (Refer to Table 1-2)  
Optional maximum operating pressure: 4000 psig  
(276 bar) (no valve, 1/4" NPT option only)

##### **Scales**

Length - 52 mm, nominal  
Types - Detachable aluminum direct reading scales in engineering and reference units

## Brooks® Ar-Mite™ MT 3750C

**Operating Fluid Temperature Limits**

Indicator: -20°F(-29°C) to 400°F (204°C)

Alarm: -20°F(-29°C) 250°F (120°C)

Transmitter: -20°F(-29°C) 180°F (82°C)

**Ambient Temperature:**

Indicator: -58°F(-50°C) to 150°F(65°C)

Alarm: -20°F(-29°C) to 150°F(65°C)

Transmitter: -20°F(-29°C) to 150°F(65°C)

(Refer to Table 1-3)

**Materials of Construction:****Process Wetted**

316L stainless steel (1.4404), Inconel® 625,

Titanium Grade II (Size 0 float only)

Optional Monel® K-500 (sizes 1-6 only)

**O-rings**

Standard: Viton® Fluoroelastomers;

Option: Buna-N, Ethylene Propylene, Kalrez®,

PTFE Teflon® (without valve)

**Enclosure Ratings**

All Housings Epoxy painted die cast aluminum

Indicator Housing: Type 4X/ IP64

Transmitter Enclosure: Type 4X/ IP66/ IP67

Reed Switch Enclosure: Type 4X

Inductive Alarm Enclosure: Type 4X/ IP65

**Connections**

Fittings Horizontal

1/4" NPT Female Threaded

1/4" Tube Compression

6 mm Tube Compression

1/4" ISO RC

(Refer to Figures 1-6 thru 1-9)

**Flanges**

DIN 2527/2635 DN15 to DN25 PN40 RF

ANSI B16.5 1/2", 3/4" or 1" - 150#, 300#, 600# RF

Vertical Inlet and Outlet Only

(Refer to Figures 1-6 thru 1-9)

**Pressure Equipment Directive (PED) 97/23/EC**

Flowmeters mentioned in this instruction manual are Sound Engineering Practice (SEP).

- Pressurized materials are manufactured in compliance with material standard ASTM.
- Applied welding method is in accordance with ASME IX / EN 287-288.
- Flowmeters are designed in accordance with ASME B31.3 and ASME B31.1
- Admissible maximum temperatures and pressure are stated further in this manual.

Table 1-1 Capacities

Meter Size	Flow Range					Viscosity Limit	Pressure Drop	
	Water		Air					
	GPH	l/h	ln/h	SCFH	m <sup>3</sup> n/h		CP	mBar
0	0.02-0.21	0.08-0.8	4-40	0.15-1.5	-	5	12	4.8
1	0.034-0.34	0.13-1.3	5.7-57	0.22-2.2	-	10	12	4.8
2	0.095-0.95	0.36-3.6	13.0-130	0.50-5.0	-	20	12	4.8
3	0.28-2.8	1.06-10.6	-	0.13-13	0.034-0.34	35	12	4.8
4	0.554-5.54	2.10-21	-	2.4-24	0.063-0.63	70	32	12.8
5	1.109-11.0	4.2-42	-	5.5-55	0.14-1.4	100	38	15.3
6	2.6-26	10.0-100	-	12-120	0.31-3.1	130	44	17.7

Table 1-2 Pressure Ratings in PSIG (Bar G)

FLANGE RATING	-20°F TO 100°F -29°C TO 39°C	200°F 93°C	300°F 149°C	400°F 204°C
150#	275 (19)	240 (16)	215 (15)	195 (13)
300#	720 (49.5)	620 (43)	560 (39)	515 (35)
600#	1440 (99)	1240 (85)	1120 (77)	1030 (71)

Table 1-3 Fluid Temperature at Ambient Temperature

MAX. AMBIENT TEMPERATURE		MAX. FLUID TEMPERATURE PER OPTION					
		INDICATOR		ALARM		TRANSMITTER	
° F	° C	° F	° C	° F	° C	° F	° C
104	40	400	204	250	120	180	82
110	43	390	199	250	120	175	79
120	49	380	193	250	120	170	76
130	54	370	187	250	120	165	74
140	60	360	182	240	115	155	68
150	65	350	176	235	112	150	65

Notes:

- At ambient temperatures less than 104°F (40°C), the maximum fluid temperature does not increase.
- Ambient temperature is limited to 150°F (65°C) maximum.

## Brooks® Ar-Mite™ MT 3750C

## 1-3 Optional Equipment

**Cartridge or NRS™ Needle Valves**

The standard cartridge needle valve can be supplied integrally mounted to the inlet fitting of the instrument. The optional NRS needle valve, also integrally mounted to the inlet fitting, provides a greater number of turns affording precision control.

**Limit Switches****Inductive Alarm Switch**

One or two electronic limit switches type SJ2-N can be installed in the indicator housing to allow initiation of signaling or switching functions on a preset flow value being reached. The SJ2-N limit switch operates as a slot initiator that is inductively actuated by a cam mounted to the pointer. Any flow value can be used for setting the limit value by sliding the switch along the slot in the mounting plate for the initiators. Minimum setting distance between two limit switches is approximately 50% of the scale range. (Refer to Figure 1-1)

Power supply	8 Vdc (Max. 15.5 Vdc)
Current consumption	active area clear: > 3 mA
Current consumption	active area obscured: < 1 mA
Self inductance	29 $\mu$ H
Self capacitance	20 nF
Max Temp:	158°F(70°C)

**Electrical classification****Intrinsically Safe:**

ATEX: KEMA 02ATEX1126 X



II 2 GD T 75°C

EEx ia IIC T6

per EN50014:1997; EN50020:1994;  
EN50281-1-1:1998

CSA: (USA and Canada) 1379260



Class I, II, III, Div. 1, Groups A thru G, T6

per CSA -157:1992 ; UL913:2002

Class I, Zone 0, Zone 1 AEx ia IIC, T6

per ANSI/ UL 2279: 1996

Ex ia IIC

per CSA E79-0:2002; CSA E79-11:2002

NEPSI: (China) GYJ05244



Ex ia IIC T6

per GB3836.1:2000; GB3836.2:2000

Non Incendive:

ATEX: KEMA 02ATEX1127



II 3 GD T 75°C

EEx nA II T6

per EN60079-15: 2003;  
EN50281-1-1:1998

CSA: (USA and Canada) 1379260



NI, Class I, II, III, Div. 2, Groups A thru G, T6  
per CSA -213:1987 ; UL1604:1995

Class I, Zone 2 AEx nA II, T6

per ANSI/ UL 2279: 1996

Ex nA II

per CSA E79-0:2002; CSA E79-15:2002

NEPSI: (China) GYJ05245



Ex nA II T6

per GB3836.1:2000; GB3836.8:2003



Figure 1-1 Model MT 3750C with Reed Switch Alarm

Brooks® Ar-Mite™ MT 3750C

**Reed Switch Alarm**

Two reed switches are installed in the alarm housing to provide signaling or switching functions when a preset flow value has been reached. The reed switches provide high, low or dual setpoints and latched output over the full range. The switches are normally adjusted to the desired flow range in the factory. Modifications to the switch settings can be made in the field, refer to Section 3-4. Minimum setting distance between two switches is approximately 40% of the scale. (Refer to Figures 1-2 and 1-3)

**Data Reed Switch**

Maximum Voltage\* 175 Vdc, 124 Vac  
 Maximum Current\* 250 mA  
 Maximum Contact Rating\* 3 Watts

(Maximum Switch Specifications)

**Electrical Classification**

Non Incendive:

Maximum Voltage 30 Vdc  
 Maximum Current 100 mA  
 Maximum Contact Rating 3 Watts

CSA (US and Canada)

 NI Class I, Div. 2, Groups A, B, C and D:  
 Class II Groups F and G, T6  
 per CSA-213: 1987; UL 1604; 1995

Intrinsic Safety:

Entity parameters

$V_{max} = U_i = 30 \text{ Vdc}$ ,  $I_{max} = I_i = 100 \text{ mA}$ ,  $C_i = 0$ ,  $L_i = 0$

CSA: (US and Canada)

 IS Class I, II, III, Div. 1, Groups A thru G, T6  
 per CSA-157:1992; UL 913:2002

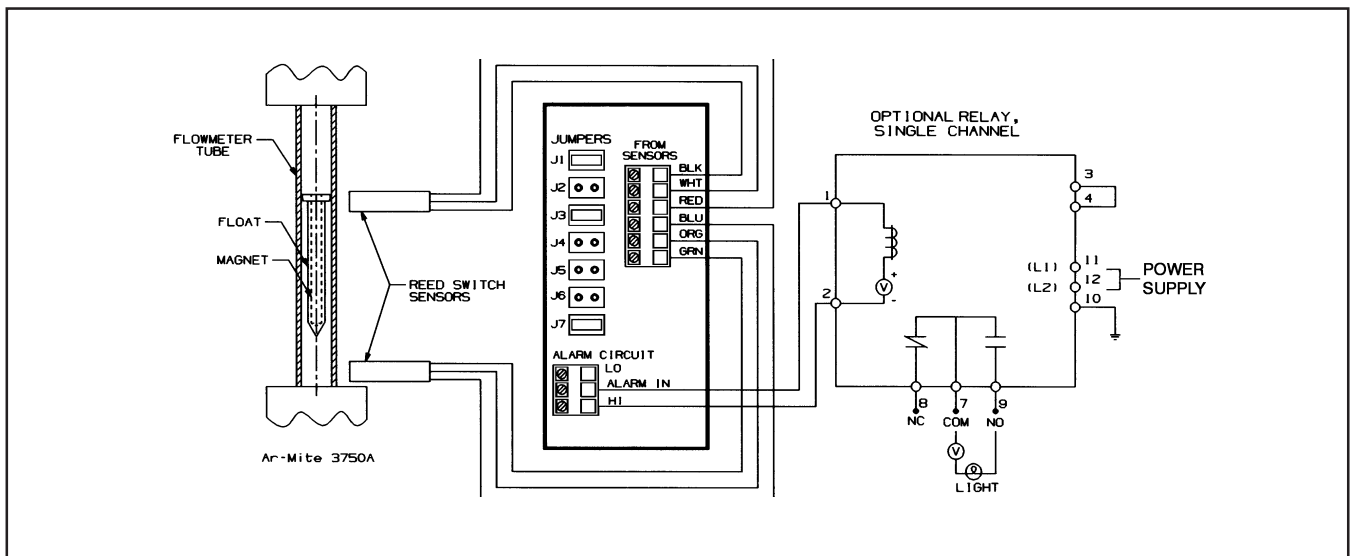

Figure 1-2 Reed Switch Wiring Diagram



Figure 1-3 Model MT 3750C with Transmitter / Inductive Alarm

**Transmitter: 3750**

The transmitter provides accurate magnet angle detection and conversion to a 4 - 20 mA industry standard output signal, based on the position of a float assembly in the flowmeter. This rugged, compact, microprocessor-driven device is capable of providing accurate flow information to your external support systems. The patented magnetic sensor with automatic gain control enables an extremely high dynamic capture range without sacrificing accuracy. (Refer to Figures 1-1, 1-4 and 1-5)

**Data Certifications:**

E.M.C. Directive 89/336/EEL according to EN 61326 (1997)

Flame-proof/ Explosion-proof:

Power Supply 28 Vdc, 4-20 mA

Ambient Temperature: -25°C ≤ Tamb ≤ 65°C

Flameproof/ Explosion-proof

ATEX: KEMA 01ATEX2174



II 2 G Ex d IIC T6

II 2 D Ex tD A 21 IP66 T 85°C

per EN 60079-0: 2006; EN 60079-1:

2004; EN61241-0: 2006;

EN61241: 2004

UL: United States and Canada UI Listed, E73889



XP Class I, Div.1, Groups A, B, C, and D, T6

DIP Class II, Div. 1, Groups E, F, and G

per UL 1203: 2000; CSA-30: 1986

Class I, Zone 1 AEx d IIC T6

per UL 2279: 1996

Ex d IIC T6

per CSA E79-0:2002; CSA E79-1:2002

NEPSI: (China) GYJ05218



Ex d IIC T6

per GB3836.1: 2000; GB3836.2: 2000

## Brooks® Ar-Mite™ MT 3750C

IECEX: KEM 06.0049

EX d IIC T6

per IEC 60079-0: 2004; IEC 60079-1: 2003

Intrinsic Safety:

## Functional parameters

Power Supply 8-28 Vdc, I<sub>max</sub>= 22 mA

## Entity Parameters:

U<sub>i</sub> = 30 V DC, I<sub>i</sub> = 100 mA    P<sub>i</sub> = 750 mWC<sub>i</sub> = 0uF    L<sub>i</sub> = 1.8 mHAmbient Temperature: -30°C ≤ T<sub>amb</sub> ≤ 65°C

ATEX: KEMA 01ATEX1033 X



II 2 GD T70°C

EEx ia IIC T6

per EN 50014: 1997 + A1, A2;

EN 50020: 2002; EN 50281-1-1: 1998+ A1

CSA: (US and Canada)



IS Class I, II, III, Div.1, Groups A, thru G, T6

per UL913:2002; CSA -157:1992

Class I, Zone 1 AEx ia IIC T6

per UL 2279:1996

Ex ia IIC T6

per CSA E79-0:2002; CSA E79-11: 2002

NEPSI: (China) GYJ05218



Ex ia IIC T6

per GB3836.1:2000; GB3836.2:2000

IECEX: KEM 06.0037

EX ia IIC T6

per IEC 60079-0: 2004; IEC 60079-11: 1999

Non IncendivePower Supply 8-28 Vdc, I<sub>max</sub>= 22 mAAmbient Temperature: -30°C ≤ T<sub>amb</sub> ≤ 65°C

ATEX: KEMA 01ATEX1035



II 3 GD T 70°C

EEx nA II T6

per EN 60079-15: 2003; EN 50281-1: 1998

CSA: (US and Canada)



NI Class I, Div.2, Grps A, B, C, and D; Class II  
Grps F and G, T6

per UL 1604: 1995; CSA-213: 1987

Class I, Zone 1 AEx nA II T6

per UL 2279: 1996

Ex nA II T6

per CSA E79-0:2002; CSA E79-15:2002

NEPSI: (China) GYJ05218



Ex na II T6

per GB3836.1: 2000; GB3836.8: 2003

IECEX: KEM 06.0037

Ex nA II T6

per IEC 60079-0: 2004; IEC 60079-15: 2005

Brooks® Ar-Mite™ MT 3750C

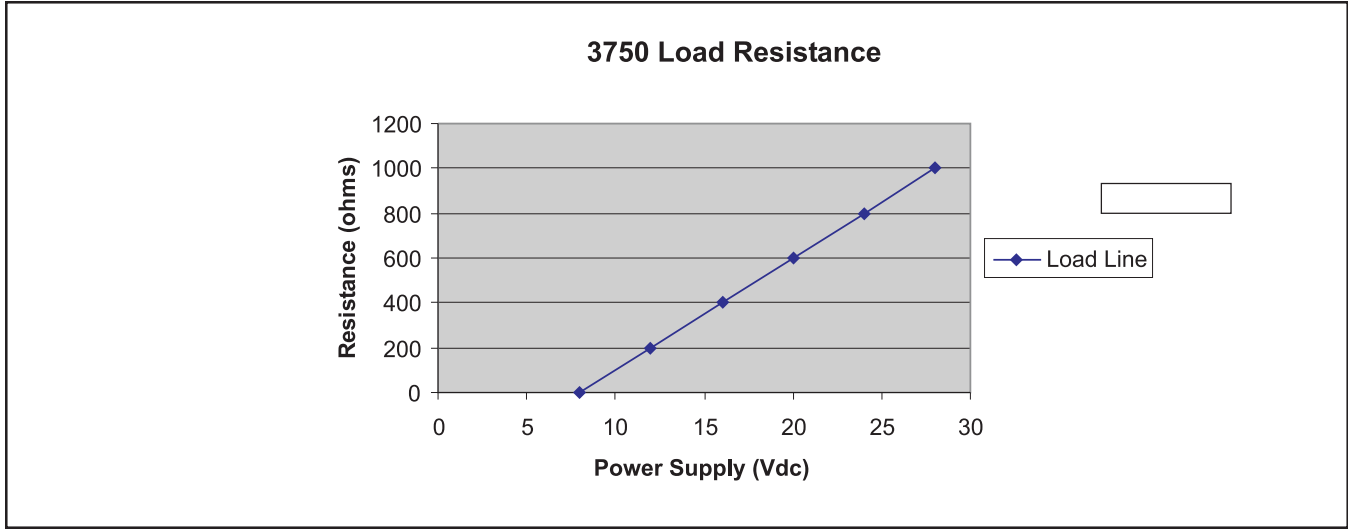

Figure 1-4 Power Supply vs. Maximum Load Resistance

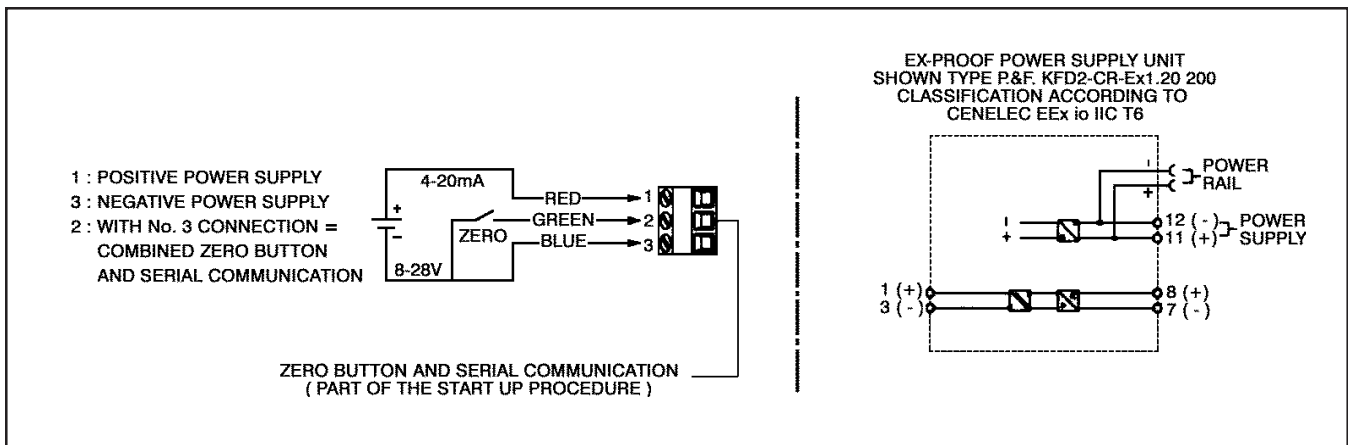

Figure 1-5 Transmitter Wiring Diagram

**⚠ CAUTION**

The transmitter is typically used with a 2 wire loop analog signal. Under normal conditions, the transmitter must always sense a static magnetic field. Failure to do this will produce an output independent on arbitrary fields like the earth's magnetic field.

**Flow Controllers**

Brooks Flow Controllers can be integrally mounted on the inlet outlet of the meter. Refer to current Flow Controller Data Sheets.

**Material certification for pressure containing**

Tube and fittings according to EN10204 Level 3.1

Valve parts and plugs are according to EN10204 Level 2.2

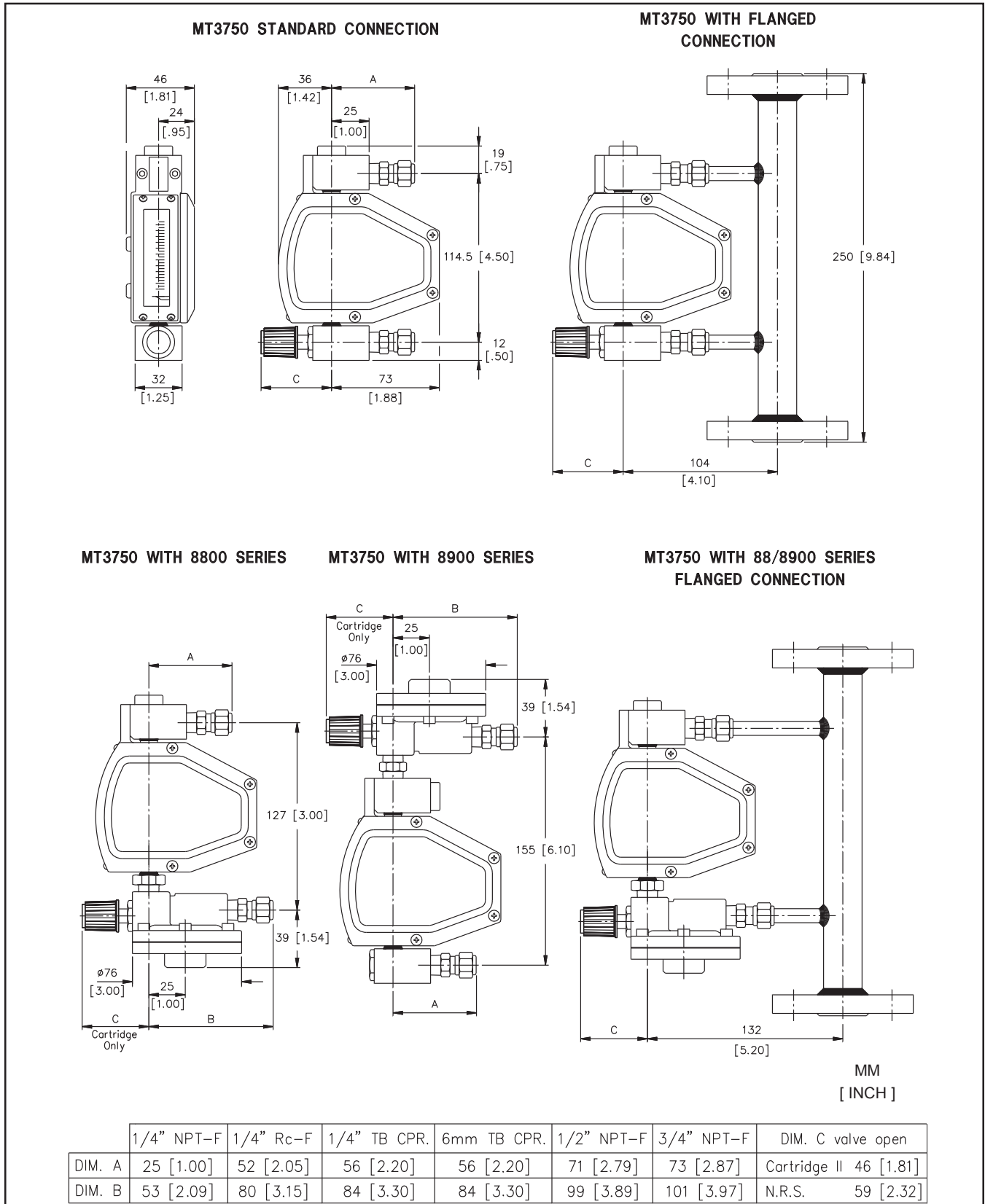

Figure 1-6 Dimensions for MT 3750C Flanged and Threaded Metal Tube Flowmeter with Indicator

Brooks® Ar-Mite™ MT 3750C

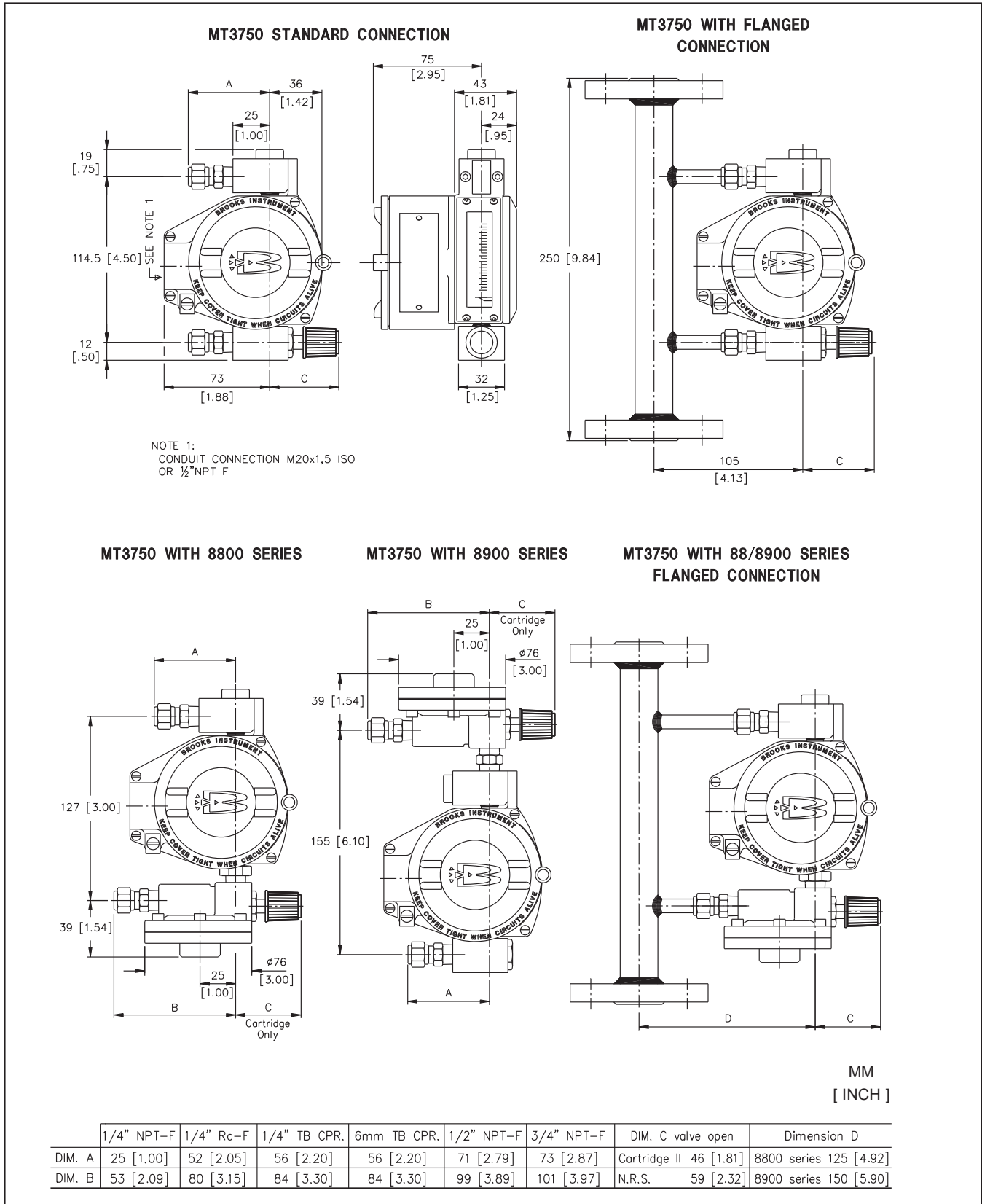

Figure 1-7 Dimensions for MT 3750C Flanged and Threaded Connections with Transmitter or Inductive Alarm

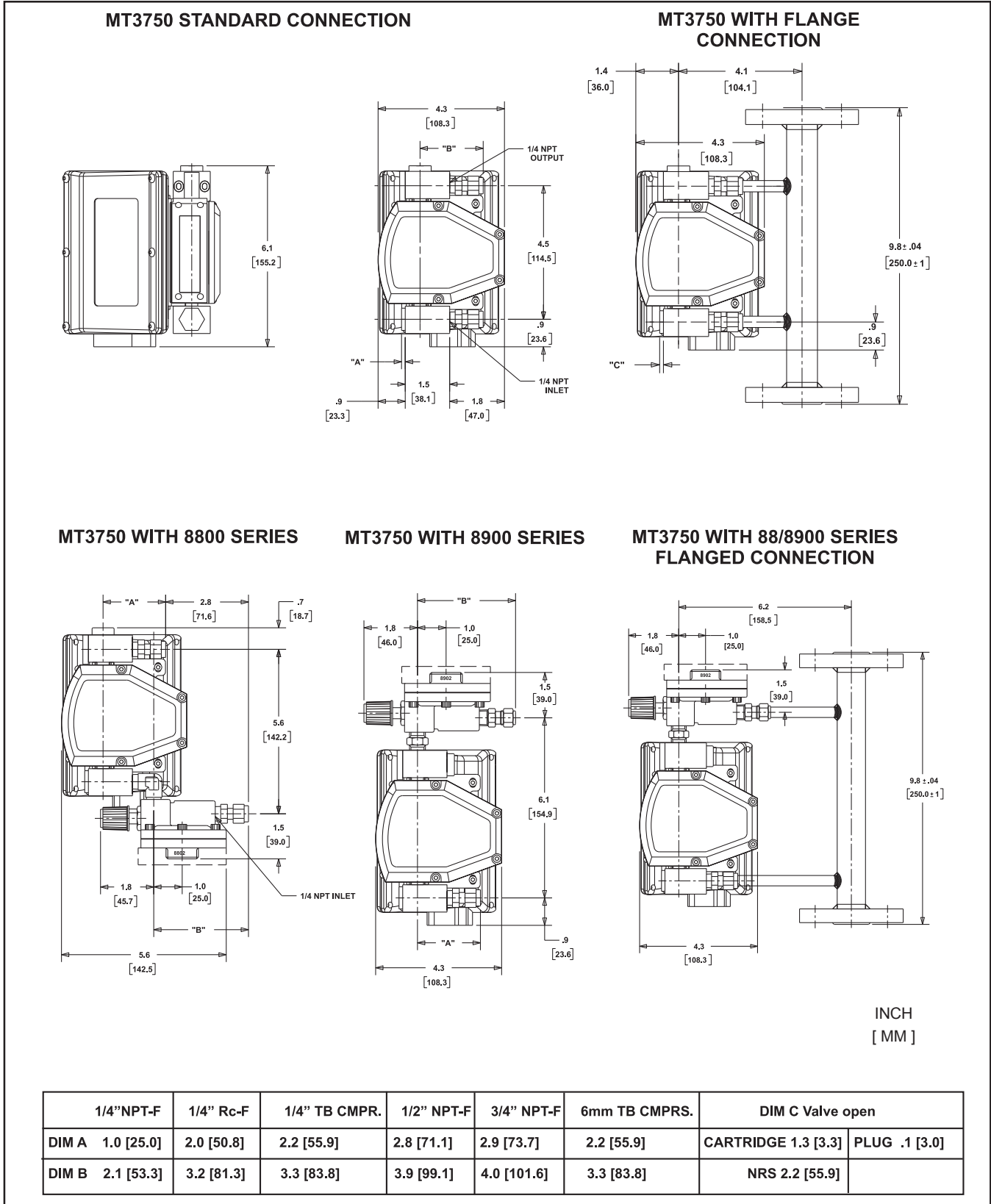

Figure 1-8 Dimensions for MT 3750C Flanged and Threaded Connections with Reed Switch Alarm

Brooks® Ar-Mite™ MT 3750C

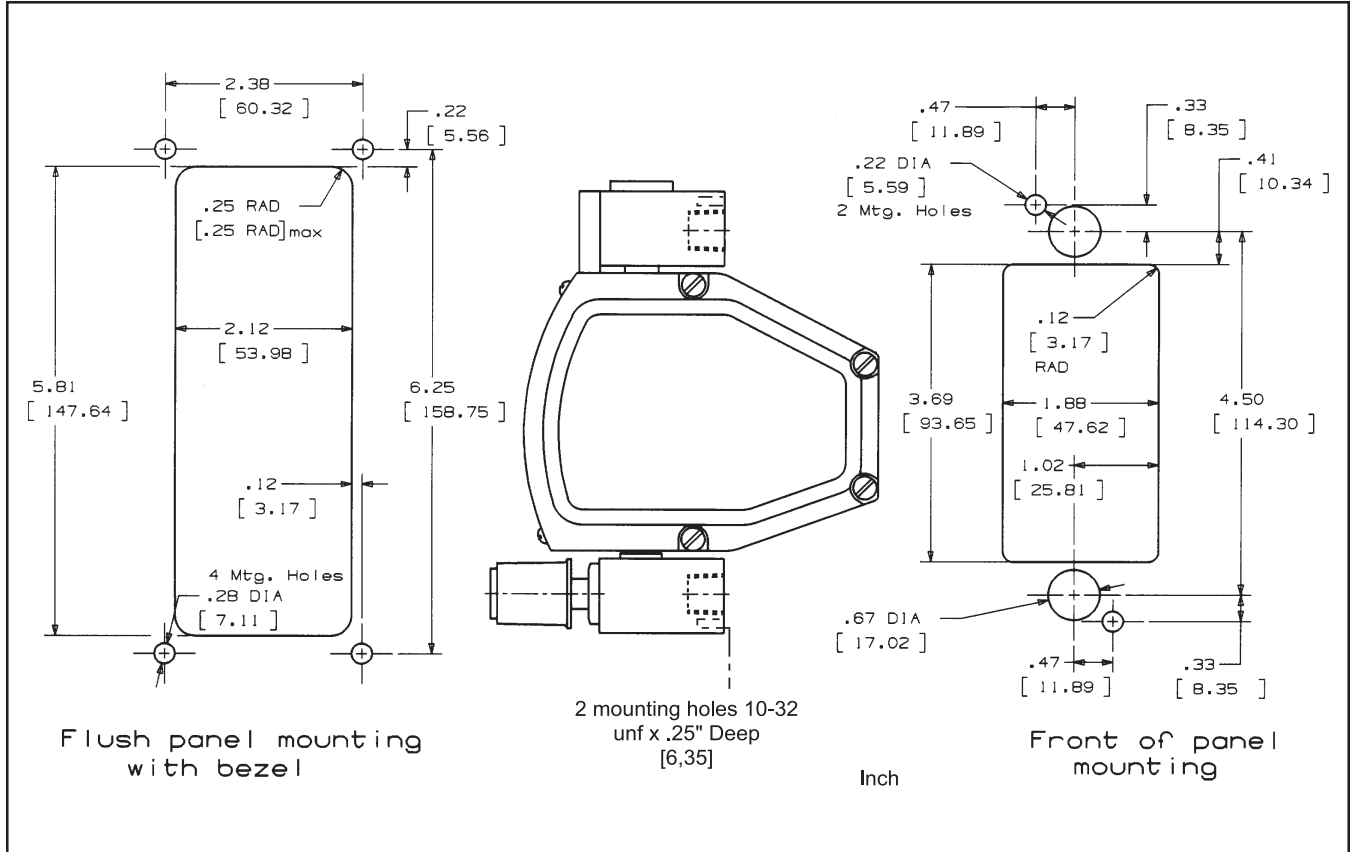

Figure 1-9 Dimensions for MT 3750C Panel Mounting

**2-1 General**

This section contains the procedures for the receipt and installation of the instrument. Do not attempt to start the system until the instrument has been permanently installed. It is extremely important that the start-up procedures be followed in the exact sequence presented.

**2-2 Receipt of Equipment**

When the instrument is received, the outside packing case should be checked for damage incurred during shipment. If the packing case is damaged, the local carrier should be notified at once regarding his liability. A report should be submitted to your nearest Product Service Department.

**Brooks Instrument**

407 W. Vine Street  
P.O. Box 903  
Hatfield, PA 19440 USA  
Toll Free (888) 554-FLOW (3569)  
Tel (215) 362-3700  
Fax (215) 362-3745  
E-mail: BrooksAm@BrooksInstrument.com  
www.BrooksInstrument.com

**Brooks Instrument**

Neonstraat 3  
6718 WX Ede, Netherlands  
P.O. Box 428  
6710 BK Ede, Netherlands  
Tel 31-318-549-300  
Fax 31-318-549-309  
E-mail: BrooksEu@BrooksInstrument.com

**Brooks Instrument**

1-4-4 Kitasuna Koto-Ku  
Tokyo, 136-0073 Japan  
Tel 011-81-3-5633-7100  
Fax 011-81-3-5633-7101  
Email: BrooksAs@BrooksInstrument.com

Remove the envelope containing the packing list. Carefully remove the instrument from the packing case. Make sure spare parts are not discarded with the packing materials. Inspect for damaged or missing parts.

**2-3 Recommended Storage Practice**

If intermediate or long-term storage of equipment is required, it is recommended that the equipment be stored in accordance with the following:

- a. Within the original shipping container.
- b. Stored in a sheltered area, preferably a warm, dry, heated warehouse.
- c. Ambient temperature of 70° F (21° C) nominal, 109° F (43° C) maximum, 45° F (7° C) minimum.
- d. Relative humidity 45% nominal, 60% maximum, 25% minimum.  
Upon removal from storage a visual inspection should be conducted to verify the condition of equipment is "as received".

## Brooks® Ar-Mite™ MT 3750C

**2-4 Return Shipment**

Prior to returning any instrument to the factory, contact your nearest Brooks location for a Return Materials Authorization Number (RMA#). This can be obtained from one of the following locations:

**Brooks Instrument**

407 W. Vine Street  
P.O. Box 903  
Hatfield, PA 19440 USA  
Toll Free (888) 554-FLOW (3569)  
Tel (215) 362-3700  
Fax (215) 362-3745  
E-mail: BrooksAm@BrooksInstrument.com  
www.BrooksInstrument.com

**Brooks Instrument**

Neonstraat 3  
6718 WX Ede, Netherlands  
P.O. Box 428  
6710 BK Ede, Netherlands  
Tel 31-318-549-300  
Fax 31-318-549-309  
E-mail: BrooksEu@BrooksInstrument.com

**Brooks Instrument**

1-4-4 Kitasuna Koto-Ku  
Tokyo, 136-0073 Japan  
Tel 011-81-3-5633-7100  
Fax 011-81-3-5633-7101  
Email: BrooksAs@BrooksInstrument.com

Instrument must have been purged in accordance with the following:

**⚠ WARNING**

**If the inlet and outlet valves adjacent to the indicator are to be closed for any reason, the indicator must be completely drained. Failure to do so may result in thermal expansion of the liquid which can rupture the meter and cause possible personal injury.**

All flow instruments returned to Brooks requires completion of Form RPR003-1, Brooks Instrument Decontamination Statement, along with a Material Safety Data Sheet (MSDS) for the fluid(s) used in the instrument. Failure to provide this information will delay processing by Brooks personnel. Copies of these forms can be downloaded from the Brooks website [www.BrooksInstrument.com](http://www.BrooksInstrument.com) or are available from any Brooks Instrument location listed above.

**2-5 Transit Precautions**

To safeguard against damage during transit, transport the instrument to the installation site in the same container used for transportation from the factory if circumstances permit.

**2-6 Removal From Storage**

Upon removal of the instrument from storage, a visual inspection should be conducted to verify its "as-received" condition. If the instrument has been subject to storage conditions in excess of those recommended (See Section 2-3), it should be subjected to a pneumatic pressure test in accordance with applicable vessel codes.

2-7 Installation of Flowmeter

**⚠ WARNING**

If the inlet and outlet valves adjacent to the indicator are to be closed for any reason, the indicator must be completely drained. Failure to do so may result in thermal expansion of the liquid which can rupture the meter and cause possible personal injury.

Recommended installation for Model MT 3750C is as follows:

- A. Carefully remove the covers from each end of the flowmeter.
- B. Install the flowmeter with the inlet at the bottom and the outlet at the top.
- C. When installing the flowmeter in the process line, follow accepted plumbing practices for flanged or threaded fittings.
- D. Install the flowmeter within 5° of true vertical. Use of a level is recommended to determine the proper alignment.
- E. Installation of a bypass piping arrangement is recommended, Refer to Figure 2-1. Bypass piping permits the meter to be isolated from the flow line for servicing and cleaning.

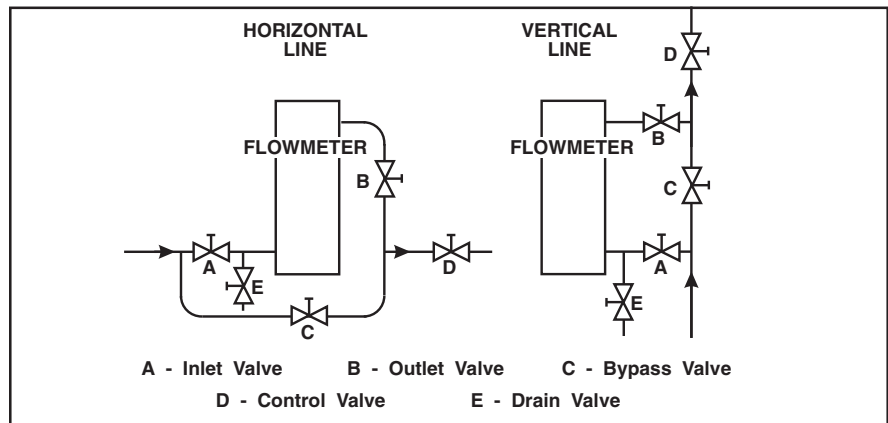

Figure 2-1 Typical Installation

**GENERAL NOTE FOR ELECTRONICS:**

The Electrical connections shall be made in such a way that the degree of ingress protection is maintained and is suitable for the installed environment. See UL 50, NEMA 250 and EN 60529. Most installations will require Type 4X or IP54 as a minimum installation.

2-8 Installation of Inductive Alarm

**⚠ WARNING**

Proper grounding of the instrument is required to avoid shock or personal injury. A terminal for grounding is provided inside the instrument identified with the symbol .

Brooks® Ar-Mite™ MT 3750C

- A. For intrinsically safe operation (recognized by a BLUE COVER), intrinsic safety barrier selection, cable parameters and power supply limits must be in accordance with the entity parameters shown on drawing.
- B. If the area classification is a Division 2 or Zone 2, a barrier is not required. Note however when intrinsic safe apparatus is used without barrier, this apparatus may **NOT** be considered as intrinsically safe. This is because input protection diodes may be damaged without affecting normal operation. It is the customers' responsibility to clearly mark the apparatus when intrinsic safety is no longer valid.
- C. Connect the IS Alarm as shown in Figures 2-2 and 2-3.

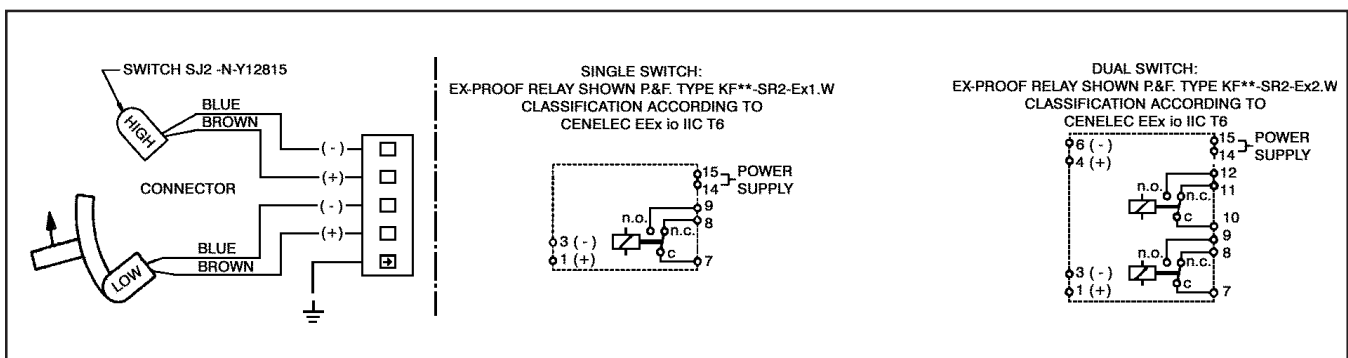



Figure 2-2 Inductive Switch Wiring Diagram

2-9 Installation of Reed Switch Alarm

**⚠ WARNING**

Proper grounding of the instrument is required to avoid shock or personal injury. A terminal for grounding is provided inside the instrument identified with the symbol .

**⚠ NOTICE**

**Class III Equipment:** The dc main input shall be supplied from a SELV (Separated Extra-Low Voltage) source.

- A. Install meter as described in Section 2-4.

**⚠ WARNING**

High voltages may be present within the intergral alarm housing. Make no adjustments to the system while power is applied. Failure to heed warning can result in serious personal injury.

- B. For Factory Mutual Approved installations and for CSA/NRTL/C Certified installations, refer to Figures 2-4 and 2-5. On the system printed circuit board is a three terminal block marked "Alarm Circuit". The middle terminal is marked "Alarm In". This terminal is common for

both high alarm and low alarm applications. A circuit is completed by connecting wires to “Alarm In” and to either “HI” for high flow alarm or “LO” for low flow alarm. Wires used should be in the range from 12 to 20 AWG. Remove 0.3 inches of insulation before inserting the wire into the terminal block and tightening the screw.

For electrical hook-up of units requiring intrinsically safe power connections, use Brooks optional power supply and relay connected as in Figure 2-6 for the integral alarm.

**2-10 Installation of Transmitter**

- A. For intrinsically safe operation (recognized by a BLUE COVER), intrinsic safety barrier selection, cable parameters and power supply limits must be in accordance with the entity parameters shown in Figure

**⚠ WARNING**

**Proper grounding of the instrument is required to avoid shock or personal injury. A terminal for grounding is provided inside the instrument identified with the symbol** 

**⚠ CAUTION**

**Since this is a magnetically activated device, strong magnetic fields and materials with magnetic properties may cause faulty operation when in close proximity to the flowmeter. This includes steel pipes, steel conduit, motors and transformers**

2-6. Do not connect the zero wire (keep it floating) when the transmitter is in normal operation. The zero wire is not meant to be extended as zeroing must be done locally.

- B. If the area classification is Division 2 and Zone 2, a barrier is not required and cable parameters are not applicable. The electrical code will require the use of conduit for wire protection. Refer to Figure 2-7.
- C. If the installation is to be protected by Division 1 and Zone 1 explosion-proof methods, explosion-proof installation methods must be followed. Refer to Figure 2-8.
- D. The power supply voltage determines the maximum resistance of the loop, the associated cable and the barrier. Always be sure that the voltage on the transmitter is within the specifications.
- E. After installation and powering of the loop, the transmitter must be zeroed to compensate for any stray magnetic effects in the vicinity of the transmitter. The zero function may be activated as part of a periodical maintenance check. The zero function is activated by momentary (>2 seconds) shorting the zero wire to the ground wire while power is on. Connect the transmitter as shown in Figure 2-9.

Brooks® Ar-Mite™ MT 3750C

Ref. No.981X211 - Rev. B Sheet 1 of 1

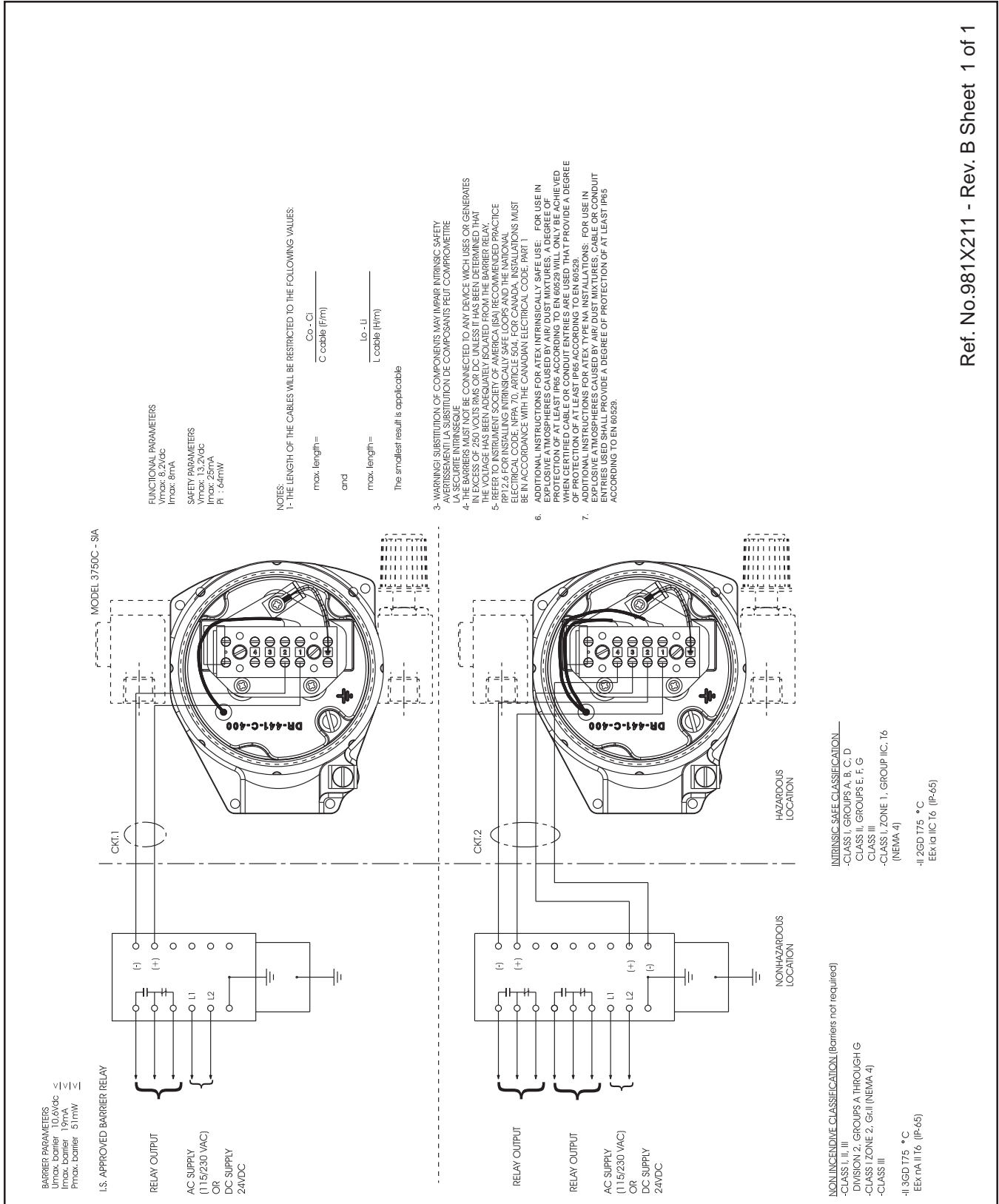

Figure 2-3 Inductive Switch Wiring

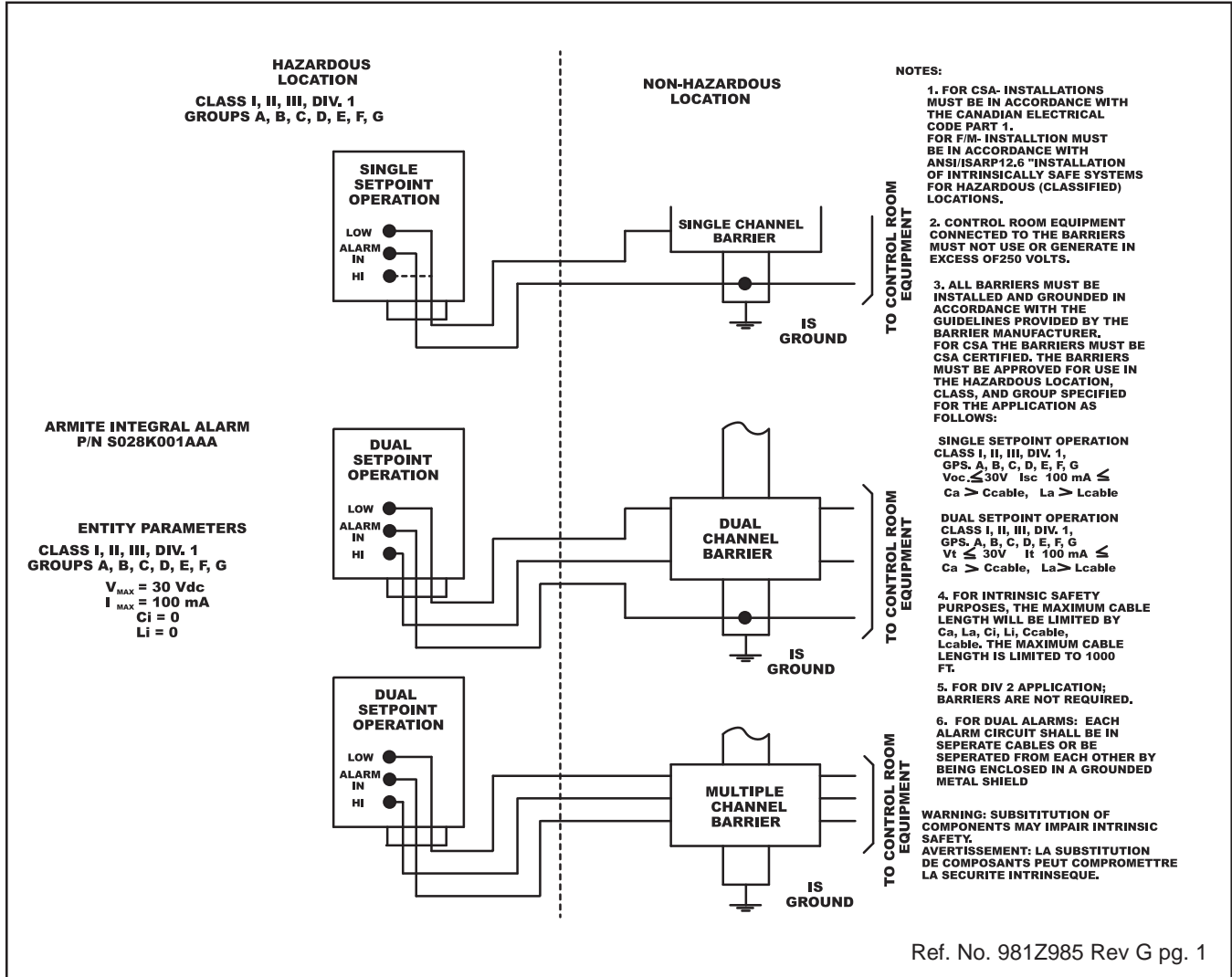

Figure 2-4 Reed Switch Alarm Installation Using IS Barriers.

**NOTICE**

The Brooks (electric/electronic) equipment bearing the CE mark has been successfully tested to the regulations of the Electro Magnetic Compatibility (EMC directive 89/336/EEC). Special attention is required when selecting the signal cable to be used with CE marked equipment.

Brooks supplies high quality cables which meet the specifications for CE certification. If you provide your own signal cable you should use a cable which is completely screened with a 100% shield. D-Connectors should also be shielded using a metal shield. If applicable, metal cable glands must be used to provide cable screen clamping. The cable screen should be connected to the metal shell or gland and shielded at both ends over 360 degrees. The shield should be terminated to an earth ground. See Appendix A for CE Certification of Mass Flow Equipment.

Brooks® Ar-Mite™ MT 3750C

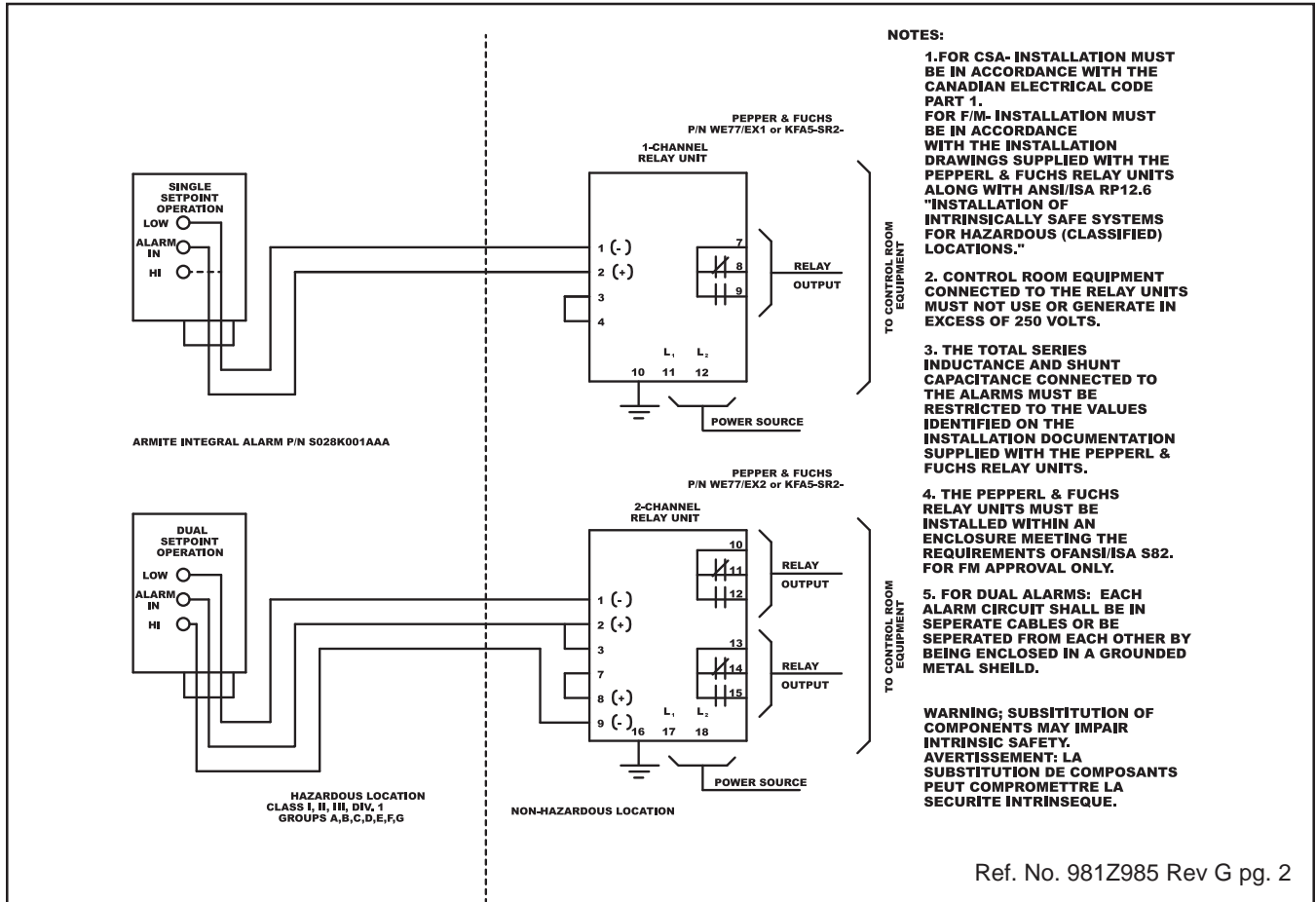
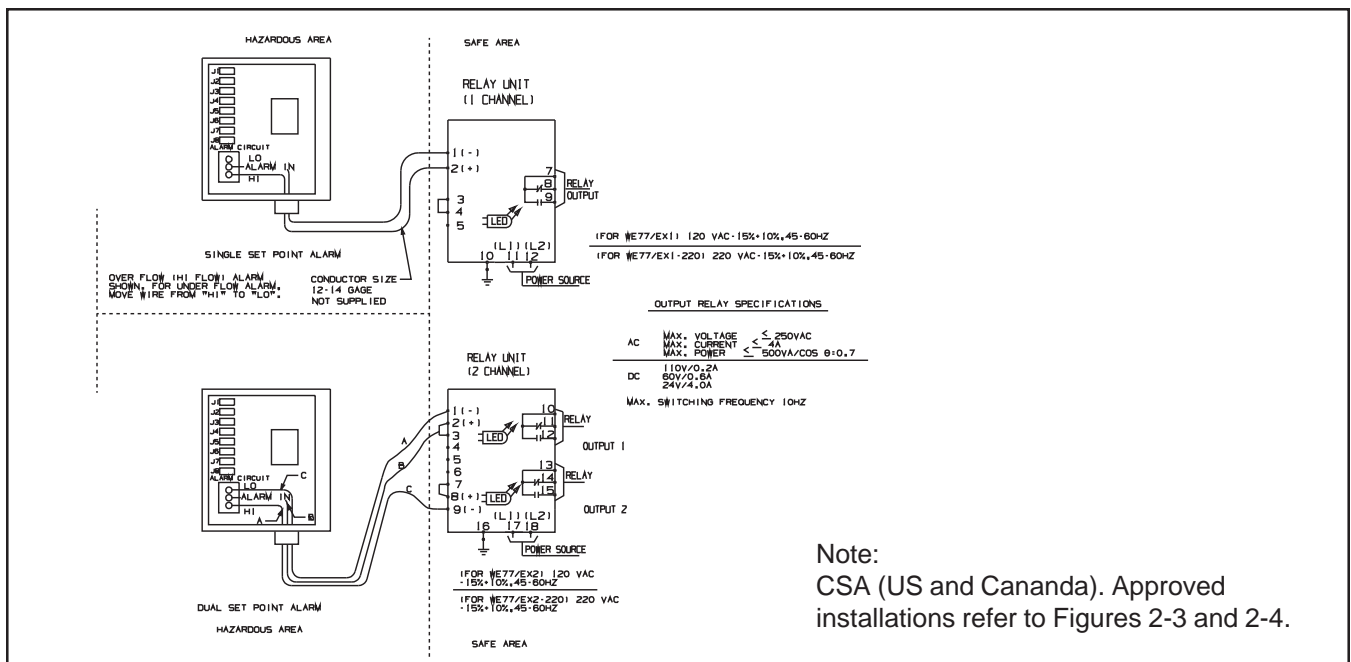

Figure 2-5 Reed Switch Alarm Installation Using P&F Relay Unit.



Note:  
 CSA (US and Canada). Approved installations refer to Figures 2-3 and 2-4.

Figure 2-6 Reed Switch Alarm Wiring Using P & F Relay Unit.

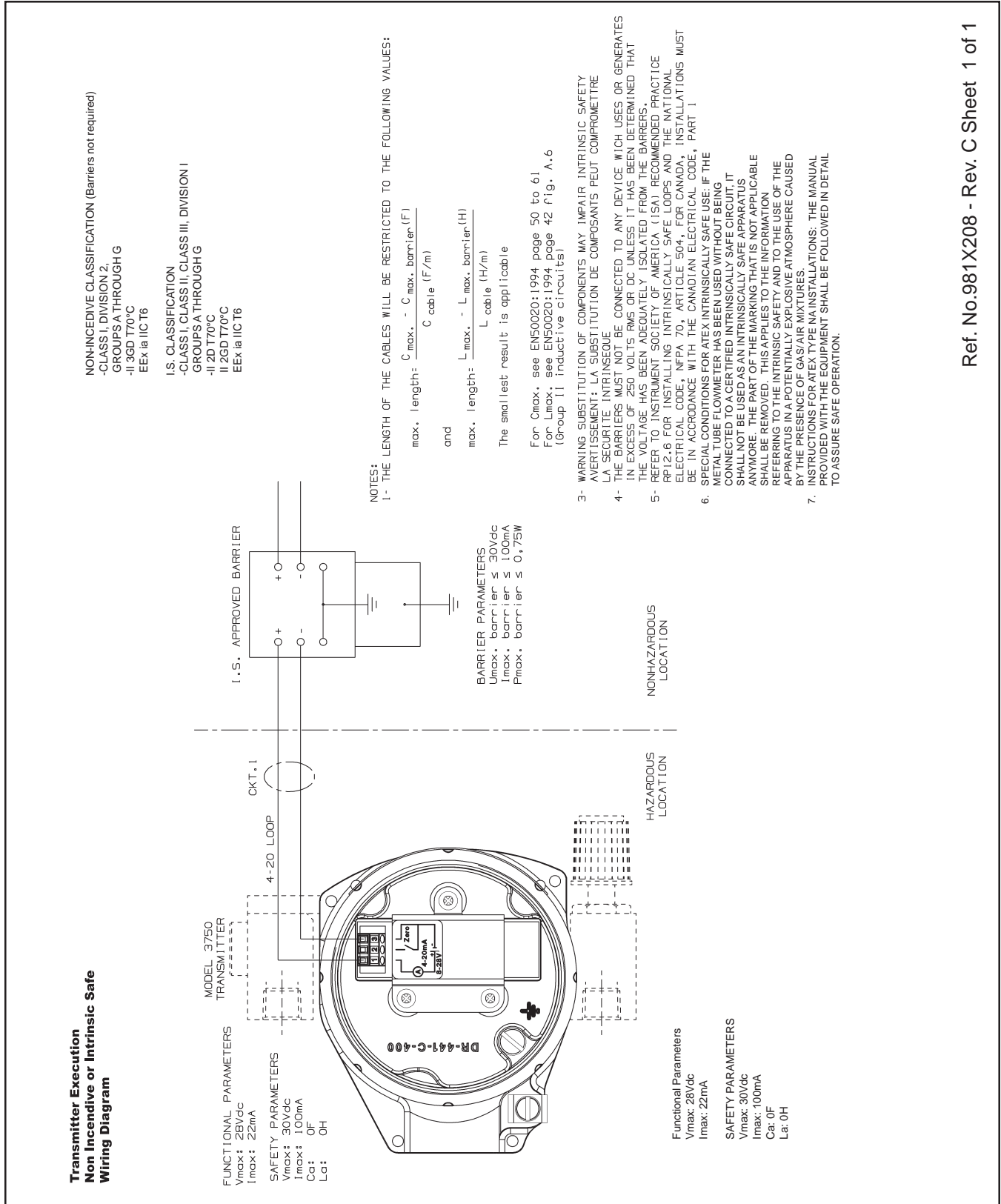

Figure 2-7 Transmitter Wiring Diagram for I.S. Systems

Brooks® Ar-Mite™ MT 3750C

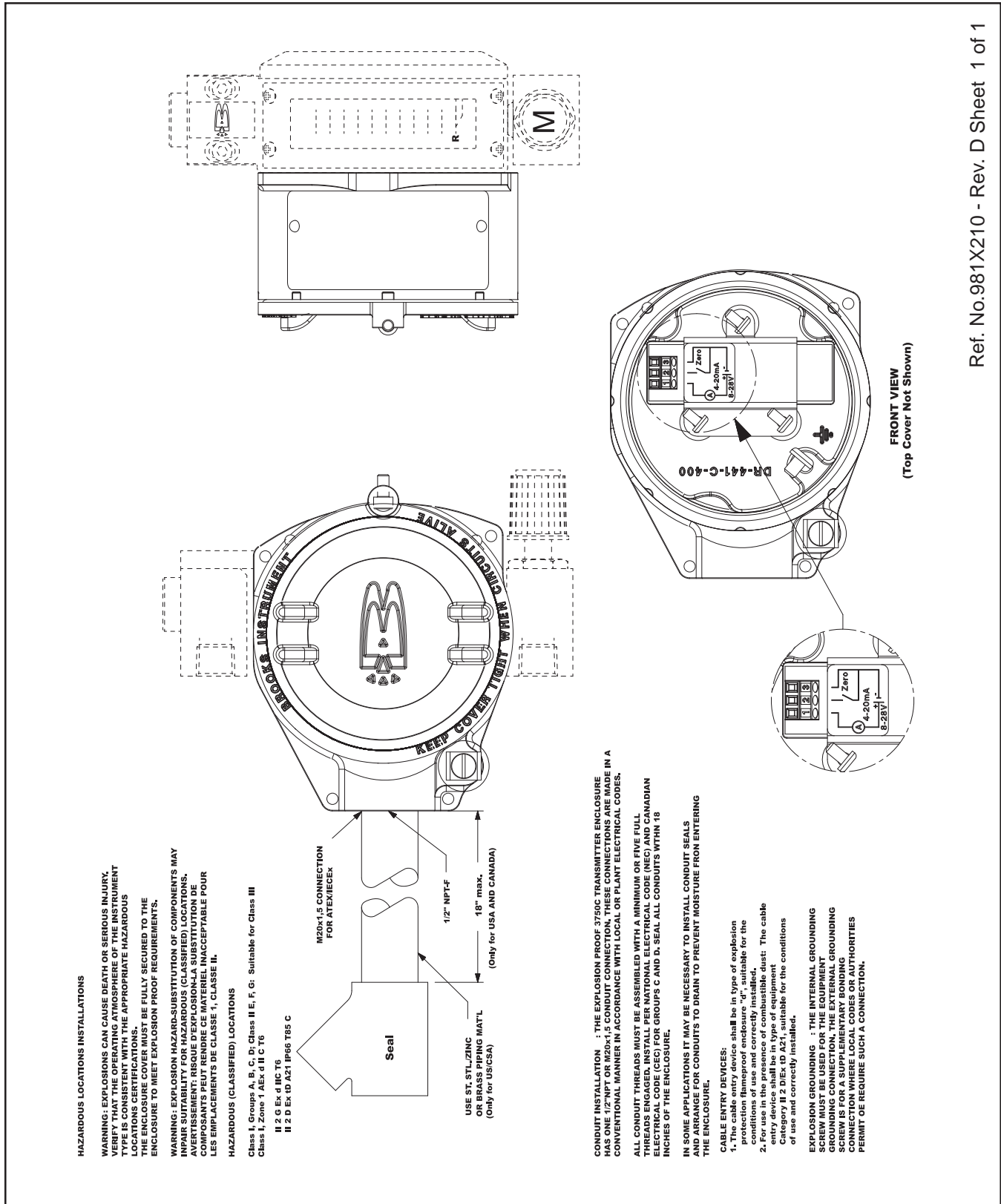

Figure 2-8 Transmitter Wiring Diagram for XP Systems

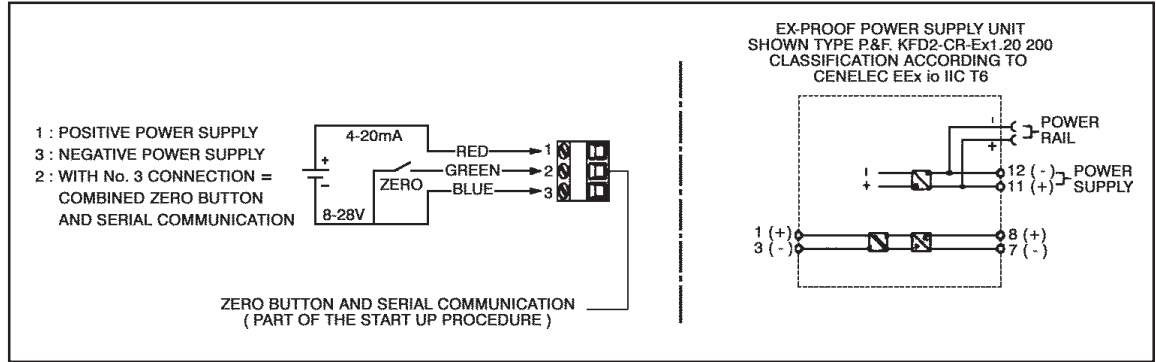

Figure 2-9 Transmitter Wiring Diagram

*THIS PAGE WAS  
INTENTIONALLY  
LEFT BLANK*

**3-1 Operating Procedure**

After the flowmeter has been properly installed in the process, it is ready for operation. When initiating flow, slowly open the valve to avoid a flow surge. Bypass is a help in bringing the flow on smoothly. Avoid starting a pump to supply the flowmeter without the use of a valve upstream of the flowmeter.

**⚠ WARNING**

**Before operating the flowmeter, ensure all fluid connections have been properly tightened and, where applicable, all electrical connections have been properly terminated.**

**3-2 Operation of Inductive Alarm**

- A. Start-up the meter as described in Section 3-1
- B. To modify the alarm set points, remove the side cover of the indicator housing by removing the four screws.
- C. Set the alarm position by loosening the screw mounting the switch to the plate.
- D. Hold the pointer to the desired alarm flow rate.
- E. Move switch assembly until the metal initiator, attached to the pointer, is not inserted into the switch.
- F. Tighten the screw mounting the switch to the plate.
- G. Replace the indicator housing cover and gasket and secure with the four screws.

**3-3 Operation of Transmitter**

- A. Start-up meter as described in Section 3-1.
- B. Programming is performed prior to shipment. The transmitter is preprogrammed prior to shipment for the following parameters based on the order information, meter configuration and application. If parameters are not specified in the customer purchase order, the defaults inherent to the electronics will be as shown in (parenthesis).

**Pre-Programmed Parameters**

- Serial Number
- Flow Rate units of measure (gpm)
- Low Flow cutoff (5% FS flow)
- Analog Output LoRange  
(4 mA @ 0% flow)
- Analog Output HiRange  
(20 mA @ 100% flow)

### 3-4 Operation of Reed Switch Alarm

#### **WARNING**

**High voltages may be present within the intergral alarm housing. Make no adjustments to the system while power is applied. Failure to heed warning can result in serious personal injury.**

A. Start-up meter as described in Section 3-1

B. Note: The alarm flow ranges specified in Table 3-1 are for reference only. Normal variations in sensors and meter scales may cause these values to shift. If the desired performance is not achieved, adjust alarm for the next nearest flow range and repeat the operation procedure. Setting the flow rate at which the alarm activates requires placing three jumpers on the system circuit board and positioning the two sensors. These combinations are listed in Table 3-1 and in the same table inside the alarm enclosure. The letters “A” and “B” in the table refer to a scale imprinted on the sensor bracket. To accurately set the alarm, it is necessary to establish flow through the meter at a rate corresponding to the desired set-point.

As an example, set the alarm for switch closure at flow rates below 50% of rated maximum flow. Disconnect any wires which are connected to the “Alarm Circuit” terminal strip. Connect an ohmmeter or continuity tester across the printed circuit board terminals marked “Alarm In” and “LO”. Find, in the table, the row marked “Low Flow 40 - 70%”. Follow the row across to the column marked “Jumpers”. In this case, the jumpers required are J1, J4, and J6. Simply pull the jumpers out from their current positions and place them in the correct three places. Apply flow to the flow meter and adjust for 50% of rated maximum flow. Loosen the adjustment screw on the lower sensor holder and move the sensor until it reaches the lowest position possible on the sensor bracket. On the sensor holders is a white index line. Loosen the adjustment screw on the upper sensor holder and move the sensor until the index line is within the region marked “A”. Watching the ohmmeter, slowly move the upper sensor within this region until a change in continuity takes place (switch closes or opens). Tighten the adjustment screw.

Fine adjustment of the set point may be required. Adjust the flow rate and observe the behavior of the system. Adjust the upper sensor up or down slightly as required to meet your requirements for accuracy. **After establishing setpoint, operate system over entire flow range to verify desired alarm performance.**

The position of the sensors along the flow tube is the only required sensor adjustment. **Adjustment of the distance between the sensor and the wall of the flow tube is made at the factory. This setting should not be altered.**

C. Two jumper configurations allow simultaneous use of both the high and low alarm circuits. In the first of these configurations, an alarm is always active. If the flow rate is under the set point, the low alarm circuit is closed. If the flow exceeds the set point, the low alarm circuit opens and the hi alarm circuit closes. There is hysteresis associated with reed switches, so the flow rates at which the alarm switches between HI and LO will be slightly different depending on whether the flow rate is increasing or decreasing.

The second “Dual” alarm option allows separately adjusting the set points for low flow alarm and high flow alarm within a limited range of the maximum flow rate of the meter.

The dual setpoint alarm is set in the same manner as described in Section 3-4. Simply use two ohmmeters to observe the behavior of both circuits.

Table 3-1 Interior Label MT 3750 Ar-Mite Alarm.

<b>Alarm Programming Table</b>			
<b>Alarm Flow Range</b>	<b>Jumper Positions</b>	<b>Adjust Upper Sensor in Region (2)</b>	<b>Lower Sensor Position</b>
High, 60-100%	J-2,5,7	B	Bottom of Slot
High, 40-75%	J-1,4,6	A	Bottom of Slot
High, 0-40%	J-1,3,5	B	Bottom of Slot
Low, 55-100%	J-2,3,7	B	Bottom of Slot
Low, 40-75%	J-1,4,6	A	Bottom of Slot
Low, 0-40%	J-1,5,7	B	Bottom of Slot
Dual: High, 40-75% Low, 30-60%	J-1,4,6	A	Bottom of Slot
Dual: High, 40-75% Low, 10-45%	J-1,6,8	A (High Set)	Region B (Low Set)

(1) These ranges for reference only.  
 (2) Final sensor position may be slightly outside of these ranges.

Brooks® Ar-Mite™ MT 3750C

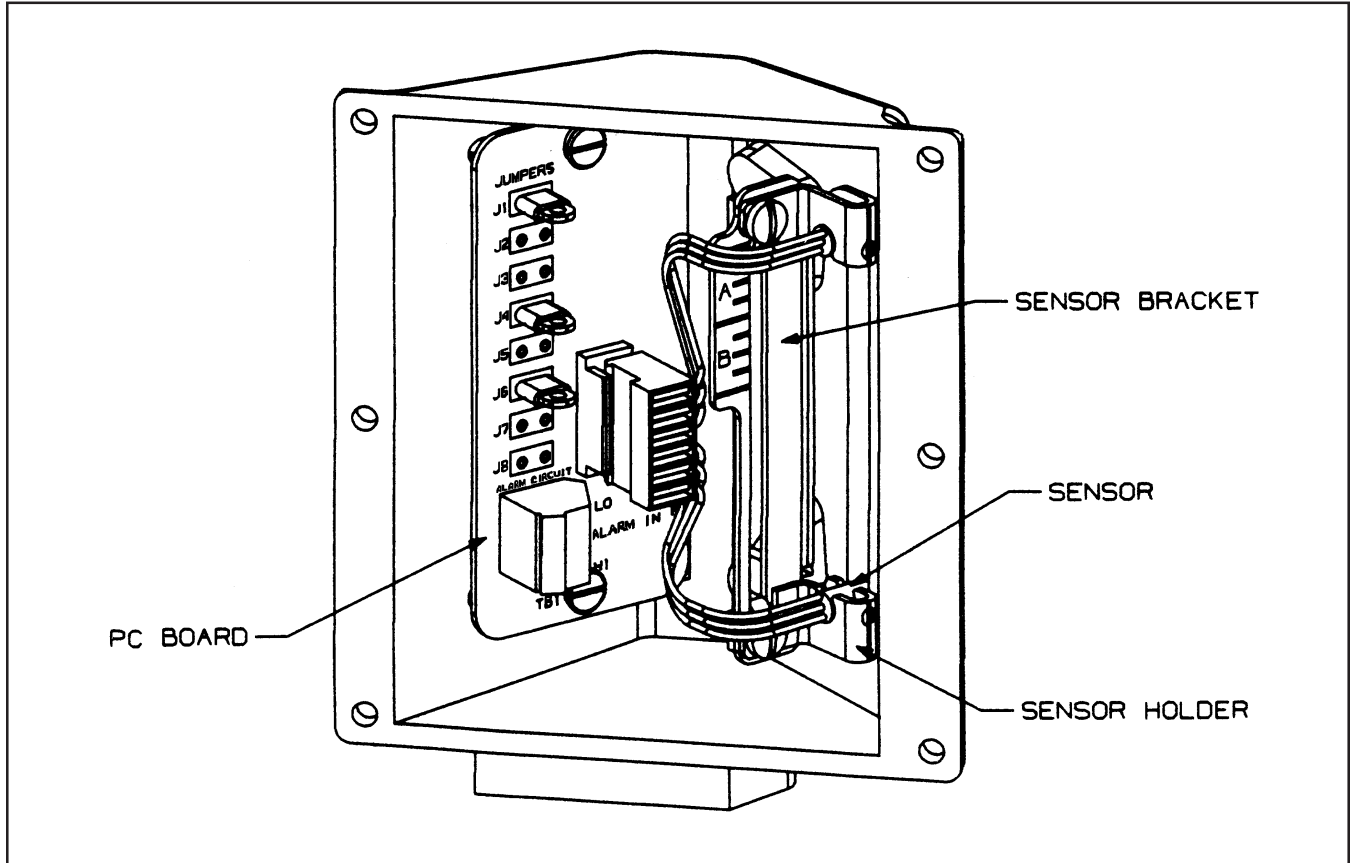



Figure 3-1 Reed Switch Alarm.

4-1 General

	<b>⚠ WARNING</b>
<b>METER/CONTROLLER SEAL COMPATIBILITY</b>	
<p>Products in this manual may contain metal or elastomeric seals, gaskets, O-rings or valve seats. It is the "user's" responsibility to select materials that are compatible with their process and process conditions. Using materials that are not compatible with the process or process conditions could result in the Meter or Controller leaking process fluid outside the pressure boundary of the device, resulting in personnel injury or death.</p> <p>It is recommended that the user check the Meter or Controller on a regular schedule to ensure that it is leak free as both metal and elastomeric seals, gaskets, O-rings and valve seats may change with age, exposure to process fluid, temperature, and /or pressure.</p>	

<b>⚠ WARNING</b>
If it becomes necessary to remove the instrument from the system power to the device is disconnected at the power supply.

<b>⚠ WARNING</b>
If it becomes necessary to remove the flowmeter from the system after exposure to toxic, pyrophoric, flammable or corrosive gas, purge the flowmeter thoroughly with a dry inert gas such as Nitrogen before disconnecting the gas connections. Failure to correctly purge the flowmeter could result in fire, explosion or death. Corrosion or contamination of the flowmeter upon exposure to air, may also occur.

<b>⚠ CAUTION</b>
It is important that this MFC/MFM only be serviced by properly trained and qualified personnel.

## Brooks® Ar-Mite™ MT 3750C

**4-2 Service Information****⚠ WARNING**

Should the equipment require repair, contact the nearest Brooks Sales/Service office. It is important that servicing is performed only by trained and qualified service personnel. If equipment is not properly serviced, serious personal injury and/or damage to the equipment could result.

**4-3 On Site Adjustment/Calibration**

The transmitter can be adjusted and/or calibrated with the help of a Windows 95/98 calibration program in combination with an applicable interface that can be plugged into any RS232 serial PC-port. The calibration data is stored in the non-volatile memory in the transmitter. After calibration the transmitter functions as a stand alone device (consult factory for more details).

PC interface is needed to calibrate the transmitter. With this interface the transmitter can be connected to the serial RS232 port of a computer. At power/start-up the transmitter is waiting (~2 seconds) for serial communication before entering normal operation. When a serial communication is established, the transmitter is instructed to sustain its low-power mode (typically 2.6 mA). In this low-power mode the transmitter is directly powered from the RS232 port without the need of an external power supply.

Software Kit (Calibration CD-ROM and RS232 Interface): partnumber: F535Y001ZZZ

**5-1 General**

---

When ordering parts, please specify:

Brooks Serial Number  
Model Number  
Part Description  
Quantity

(Refer to Figure 5-1, and Tables 5-1, 5-2).

Brooks® Ar-Mite™ MT 3750C

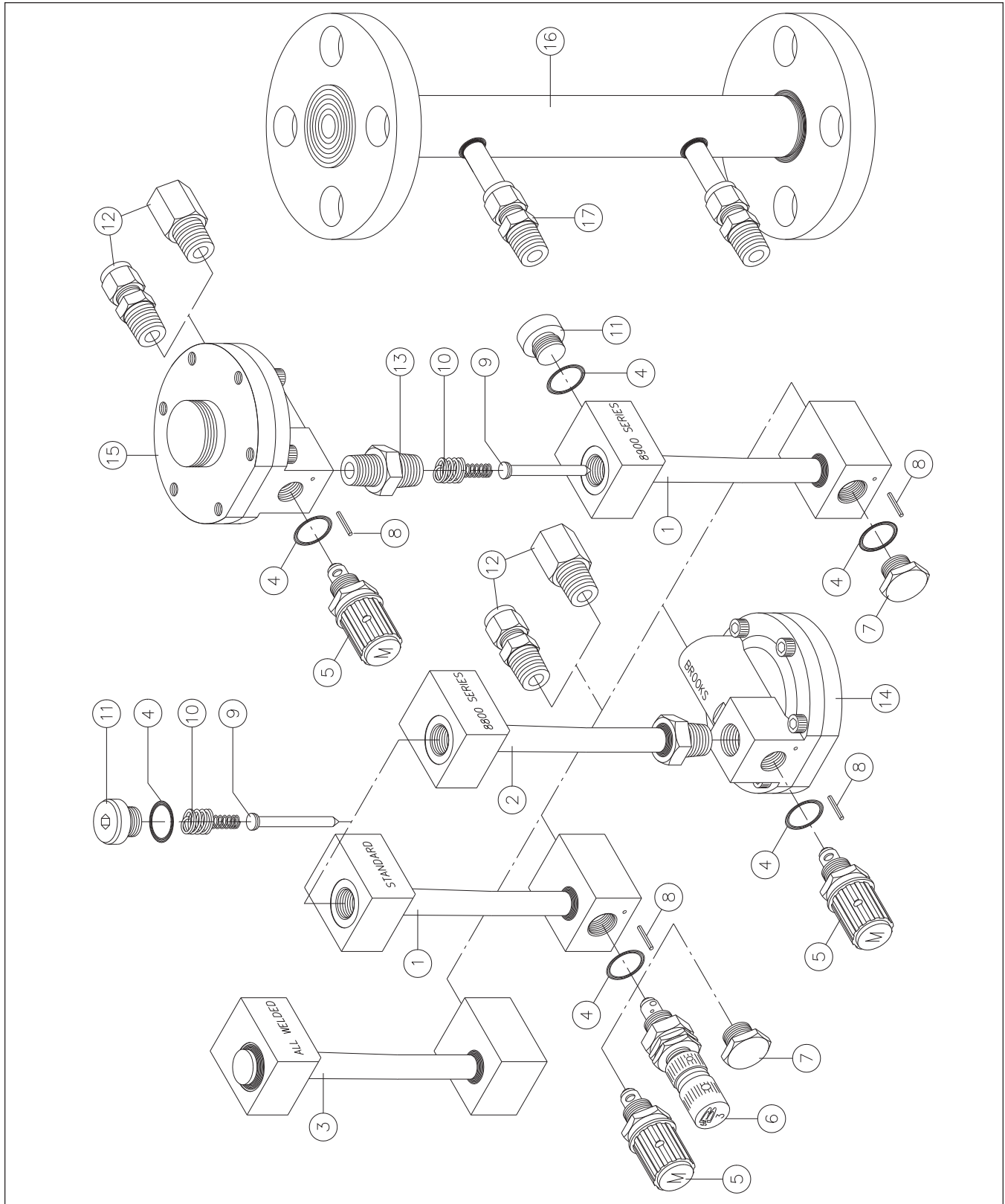

Figure 5-1 Model MT 3750 Exploded View

*Table 5-1 Model MT 3750 Recommended Spare Parts List (Refer to Figure 5-1)*

<b>POS.</b>	<b>QTY.</b>	<b>Description</b>
4	2	O-ring size 015 Viton
4	2	O-ring size 015 Buna
4	2	O-ring size 015 EPDM
4	2	O-ring size 015 Teflon
5	1	Cartridge valve low flow, Viton O-rings
5	1	Cartridge valve medium flow, Viton O-rings
5	1	Cartridge valve high flow, Viton O-rings
5	1	Cartridge valve low flow, Buna O-rings
5	1	Cartridge valve medium flow, Buna O-rings
5	1	Cartridge valve high flow, Buna O-rings
5	1	Cartridge valve low flow, EPR O-rings
5	1	Cartridge valve medium flow EPR O-rings
5	1	Cartridge valve high flow EPR O-rings
5	1	Cartridge valve low flow Teflon/Kalrez O-rings
5	1	Cartridge valve medium flow Teflon/Kalrez O-rings
5	1	Cartridge valve high flow Teflon/Kalrez O-rings
6	1	NRS #3 valve, Viton O-rings
6	1	NRS #4 valve, Viton O-rings
6	1	NRS #5 valve, Viton O-rings
6	1	NRS #6 valve, Viton O-rings
6	1	NRS #7 valve, Viton O-rings
6	1	NRS #3 valve, Buna O-rings
6	1	NRS #4 valve, Buna O-rings
6	1	NRS #5 valve, Buna O-rings
6	1	NRS #6 valve, Buna O-rings
6	1	NRS #7 valve, Buna O-rings
6	1	NRS #3 valve, EPR O-rings
6	1	NRS #4 valve, EPR O-rings
6	1	NRS #5 valve, EPR O-rings
6	1	NRS #6 valve, EPR O-rings
6	1	NRS #7 valve, EPR O-rings
6	1	NRS #3 valve, Teflon/Kalrez O-rings
6	1	NRS #4 valve, Teflon/Kalrez O-rings
6	1	NRS #5 valve, Teflon/Kalrez O-rings
6	1	NRS #6 valve, Teflon/Kalrez O-rings
6	1	NRS #7 valve, Teflon/Kalrez O-rings
7	1	Inlet O-rings seal plug
8	1	Lock pin for valve/plug
9	1	Float assy Model MT 3750; #0
9	1	Float assy Model MT 3750; #1 thru 6
10	1	Outlet float stop spring
11	1	Outlet O-ring seal plug

## Brooks® Ar-Mite™ MT 3750C

Table 5-2 Model MT 3750 Indicator, Alarm and Transmitter Spare Parts List

QTY.	Description
1	Scale Model MT3750
1	Indicator Cover MT3750
1	KFA relay Ex 1W, 220V/50Hz Intrinsically safe
1	KFA relay Ex 2W, 220V/50Hz Intrinsically safe
1	KFA relay Ex 1W, 110V/60Hz Intrinsically safe
1	KFA relay Ex 2W, 110V/60Hz Intrinsically safe
1	KFD 2 CR Ex 1.20 200, 24 Vdc Intrinsically safe
1	KFA 6-STR-1.24.500 *
1	Pointer assy standard indicator
1	Pointer assy for alarm
1	Sleeve Initiator
1	Indicator Cover Gasket
4	Indicator Cover Mounting screws
1	Alarm, Transmitter Cover O-ring
1	Transmitter assembly
1	Alarm, Transmitter Fixation screw
1	Reed Switch Alarm assembly

**\* Note:**

Power Supply Unit 110/220 AC input to 24 Vdc output to feed KFD 2 CR Ex 1.20 200

# Installation and Operation Manual

X-VA-MT 3750C-eng  
Part Number: 541B063  
October, 2008

Brooks® Ar-Mite™ MT 3750C

---

*THIS PAGE WAS  
INTENTIONALLY  
LEFT BLANK*

Brooks® Ar-Mite™ MT 3750C

LIMITED WARRANTY

Seller warrants that the Goods manufactured by Seller will be free from defects in materials or workmanship under normal use and service and that the Software will execute the programming instructions provided by Seller until the expiration of the earlier of twelve (12) months from the date of initial installation or eighteen (18) months from the date of shipment by Seller. Products purchased by Seller from a third party for resale to Buyer ("Resale Products") shall carry only the warranty extended by the original manufacturer.

All replacements or repairs necessitated by inadequate preventive maintenance, or by normal wear and usage, or by fault of Buyer, or by unsuitable power sources or by attack or deterioration under unsuitable environmental conditions, or by abuse, accident, alteration, misuse, improper installation, modification, repair, storage or handling, or any other cause not the fault of Seller are not covered by this limited warranty, and shall be at Buyer's expense.

Goods repaired and parts replaced during the warranty period shall be in warranty for the remainder of the original warranty period or ninety (90) days, whichever is longer. This limited warranty is the only warranty made by Seller and can be amended only in a writing signed by an authorized representative of Seller.

BROOKS SERVICE AND SUPPORT

Brooks is committed to assuring all of our customers receive the ideal flow solution for their application, along with outstanding service and support to back it up. We operate first class repair facilities located around the world to provide rapid response and support. Each location utilizes primary standard calibration equipment to ensure accuracy and reliability for repairs and recalibration. The primary standard calibration equipment to calibrate our flow products is certified by our local Weights and Measures Authorities and traceable to the relevant International Standards.

Visit www.BrooksInstrument.com to locate the service location nearest to you.

START-UP SERVICE AND IN-SITU CALIBRATION

Brooks Instrument can provide start-up service prior to operation when required.

For some process applications, where ISO-9001 Quality Certification is important, it is mandatory to verify and/or (re)calibrate the products periodically. In many cases this service can be provided under in-situ conditions, and the results will be traceable to the relevant international quality standards.

CUSTOMER SEMINARS AND TRAINING

Brooks Instrument can provide customer seminars and dedicated training to engineers, end users and maintenance persons. Please contact your nearest sales representative for more details.

HELP DESK

In case you need technical assistance:

- Americas 1-888-554-FLOW
Europe +(31) 318 549 290 Within Netherlands 0318 549 290
Asia +011-81-3-5633-7100

Due to Brooks Instrument's commitment to continuous improvement of our products, all specifications are subject to change without notice.

TRADEMARKS

Table listing trademarks such as Ar-Mite, Brooks, Inconel, Kalrez, Monel, NRS, Locquic, Loctite, Teflon, and Viton, along with their respective owners like Brooks Instrument, LLC, Inco Alloys International, Inc., and DuPont.

Brooks Instrument
407 West Vine Street
P.O. Box 903
Hatfield, PA 19440-0903 USA
T (215) 362-3700
F (215) 362-3745
E-Mail BrooksAm@BrooksInstrument.com
www.BrooksInstrument.com

Brooks Instrument
Neonstraat 3
6718 WX Ede, Netherlands
T 31-318-549-300
F 31-318-549-309
E-Mail BrooksEu@BrooksInstrument.com

Brooks Instrument
1-4-4 Kitasuna Koto-Ku
Tokyo, 136-0073 Japan
T 011-81-3-5633-7100
F 011-81-3-5633-7101
E-Mail BrooksAs@BrooksInstrument.com

